

TM 10-5430-240-13&P

TECHNICAL MANUAL

OPERATOR, UNIT, AND DIRECT SUPPORT MAINTENANCE MANUAL
(INCLUDING REPAIR PARTS AND SPECIAL TOOLS LIST)

TANK, FABRIC, COLLAPSIBLE, WATER, 3,000 AND
5,000 GALLONS, SEMI-TRAILER MOUNTED

3,000 GALLONS

MODEL PD62783-3000 (EIC = ZJP) NSN 5430-01-181-4071
MODEL 91093 (EIC = ZFX) NSN 5430-01-372-6901

5,000 GALLONS

MODEL PD62783-4750 (EIC = ZJJ) NSN 5430-01-120-7823
MODEL 91094 (EIC = ZFY) NSN 5430-01-372-6900

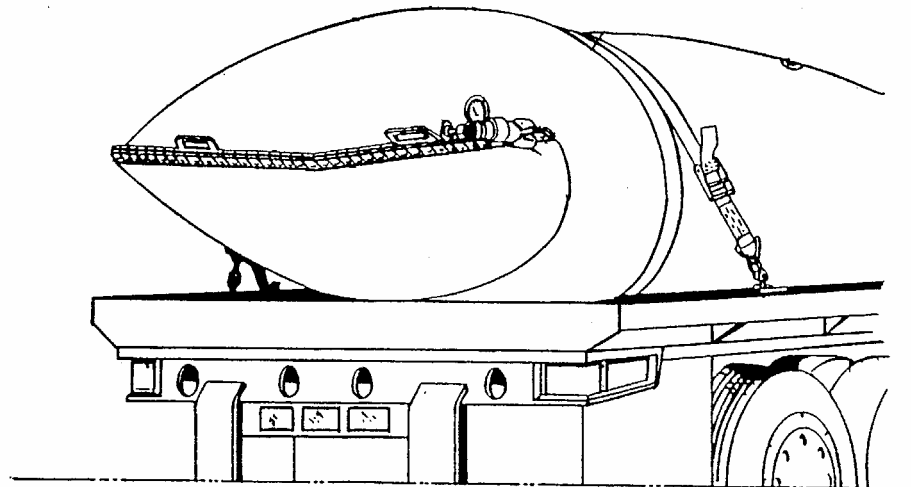

This manual supersedes TM 5-5430-212-13&P dated 15 September 1986 and TM 5-5430-213-13&P, dated 27 October 1986, including all changes.

DISTRIBUTION STATEMENT A: Approved for public release; distribution is unlimited

HEADQUARTERS, DEPARTMENT OF THE ARMY

FEBRUARY 2002

LIST OF EFFECTIVE PAGES/WORK PACKAGES

Date of issue for the original manuals and change pages are:

Original 5 February 2002

TOTAL NUMBER OF PAGES FOR FRONT AND REAR MATTER IS 30 AND TOTAL NUMBER OF WORK PACKAGES IS 36, CONSISTING OF THE FOLLOWING:

| Page/WP No. | Change No. | Page/WP No. | Change No. |
|-----------------------|------------|----------------------------|------------|
| A/B blank | 0 | WP 0016 00 (2 pages) | 0 |
| Warnings | 0 | WP 0017 00 (4 pages) | 0 |
| Title page | 0 | WP 0018 00 (2 pages) | 0 |
| i-iv blank | 0 | WP 0019 00 (4 pages) | 0 |
| WP 0001 00 (2 pages) | 0 | WP 0020 00 (2 pages) | 0 |
| Chapter 1 title page | 0 | WP 0021 00 (4 pages) | 0 |
| WP 0002 00 (4 pages) | 0 | WP 0022 00 (4 pages) | 0 |
| WP 0003 00 (2 pages) | 0 | Chapter 6 title page | 0 |
| Chapter 2 title page | 0 | WP 0023 00 (2 pages) | 0 |
| WP 0004 00 (2 pages) | 0 | WP 0024 00 (2 pages) | 0 |
| WP 0005 00 (14 pages) | 0 | WP 0025 00 (2 pages) | 0 |
| WP 0006 00 (6 pages) | 0 | Chapter 7 title page | 0 |
| Chapter 3 title page | 0 | WP 0026 00 (2 pages) | 0 |
| WP 0007 00 (4 pages) | 0 | WP 0027 00 (6 pages) | 0 |
| WP 0008 00 (4 pages) | 0 | WP 0028 00 (6 pages) | 0 |
| WP 0009 00 (2 pages) | 0 | WP 0029 00 (22 pages) | 0 |
| Chapter 4 title page | 0 | WP 0030 00 (2 pages) | 0 |
| WP 0010 00 (4 pages) | 0 | WP 0031 00 (2 pages) | 0 |
| WP 0011 00 (2 pages) | 0 | WP 0032 00 (4 pages) | 0 |
| Chapter 5 title page | 0 | WP 0033 00 (2 pages) | 0 |
| WP 0012 00 (2 pages) | 0 | WP 0034 00 (2 pages) | 0 |
| WP 0013 00 (2 pages) | 0 | WP 0035 00 (2 pages) | 0 |
| WP 0014 00 (2 pages) | 0 | WP 0036 00 (2 pages) | 0 |
| WP 0015 00 (4 pages) | 0 | Glossary 1 thru Glossary 2 | 0 |
| | | Index 1 thru Index 4 | 0 |

*Zero in this column indicates an original page.

A/B blank

WARNING SUMMARY

This warning summary contains general safety warnings and hazardous materials warnings that must be understood and applied during operation and maintenance of this equipment. Failure to observe these precautions could result in serious injury or death to personnel.

This tank can only be transported full or empty. A partially filled tank being transported will result in load shifting (surge) and will result in the reduction of vehicle control and possible rupture of the tank wall, resulting in serious injury or death.

HEALTH HAZARD

The solvent and adhesive furnished in the repair kit are highly flammable, and toxic to the skin, eyes, and respiratory tract. Skin/eye protection is required. Avoid prolonged breathing of vapors, and minimize skin contact. Good general ventilation is normally adequate. Keep away from excessive heat, open flame, or other sources of ignition

Clean parts in a well-ventilated area. Avoid inhalation of solvent fumes and prolonged exposure to cleaning solvent. Wash exposed skin thoroughly. Solvent used to clean parts is potentially dangerous to personnel and property. Do not use near open flame or excessive heat.

Use tank for drinking water only. Other liquids will contaminate tank and could cause personal injury.

Before using this equipment, the operator should be thoroughly familiar with the operating instructions. Failure to comply with this requirement may damage the equipment and jeopardize the safety of operating personnel.

The tank is drained by gravity or suction pump only. Use of air pressure to unload tank is not authorized as it may cause the tank to burst under pressure.

Do not overfill tank. Ensure filling assembly coupling is installed correctly or the tank/coupling may burst and cause personal injury

Do not air test tank. Over pressurization could cause tank to burst, resulting in serious injury or death.

FOR ARTIFICIAL RESPIRATION, REFER TO FM 21-11.

HEADQUARTERS
DEPARTMENT OF THE ARMY
WASHINGTON, D.C., 5 February 2002

TECHNICAL MANUAL

OPERATOR, UNIT, AND DIRECT SUPPORT MAINTENANCE MANUAL (Including Repair Parts and Special Tools List)

TANK, FABRIC, COLLAPSIBLE, WATER, 3,000 AND 5,000 GALLONS, SEMI-TRAILER MOUNTED

3,000 GALLON

MODEL PD62783-3000 (EIC = ZJP) NSN 5430-01-181-4071
MODEL 91093 (EIC = ZFX) NSN 5430-01-372-6901

5,000 GALLON

MODEL PD62783-4750 (EIC = ZJJ) NSN 5430-01-120-7823
MODEL 91094 (EIC = ZFY) NSN 5430-01-372-6900

Current as of 30 August 2001

REPORTING ERRORS AND RECOMMENDING IMPROVEMENTS

You can help improve this publication. If you find any mistakes or if you know of a way to improve the procedures, please let us know. Submit your DA Form 2028 (Recommended Changes to Publications and Blank Forms), through the Internet, on the Army Electronic Product Support (AEPS) website. The Internet address is <http://aeeps.ria.army.mil>. If you need a password, scroll down and click on "ACCESS REQUEST FORM". The DA Form 2028 is located in the ONLINE FORMS PROCESSING section of the AEPS. Fill out the form and click on SUBMIT. Using this form on the AEPS will enable us to respond quicker to your comments and better manage the DA Form 2028 program. You may also mail, fax or email your letter, or DA Form 2028 direct to: AMSTA-LC-CI/TECH PUBS, TACOM-RI, 1 Rock Island Arsenal, Rock Island, IL 61299-7630. The email address is TACOM-TECH-PUBS@ria.army.mil. The fax number is DSN 793-0726 or Commercial (309) 782-0726

This manual supersedes TM 5-5430-212-13&P, dated 15 September 1986, and TM 5-5430-213-13&P dated 27 October 1986, including all changes.

DISTRIBUTION STATEMENT A – Approved for public release; distribution is unlimited.

TABLE OF CONTENTS

WP Sequence No.

WARNING SUMMARY

HOW TO USE THIS MANUAL

| | |
|---|---------|
| General Information | 0001 00 |
| CHAPTER 1- Description and Theory of Operation | |
| Equipment Description and Data | 0002 00 |
| Theory of Operation | 0003 00 |
| CHAPTER 2- Operator Instructions | |
| Description and Use of Operator Controls and Indicators | 0004 00 |
| Operation Under Usual Conditions | 0005 00 |
| Operation Under Unusual Conditions | 0006 00 |
| CHAPTER 3- Troubleshooting Procedures | |
| Operator Troubleshooting Procedures..... | 0007 00 |
| Unit Troubleshooting Procedures | 0008 00 |
| Direct Support Troubleshooting Procedures..... | 0009 00 |
| CHAPTER 4- Operator Maintenance Instructions | |
| PMCS Procedures Introduction | 0010 00 |
| Operator Maintenance Procedures..... | 0011 00 |
| CHAPTER 5- Unit Maintenance Instructions | |
| Lubrication Instructions | 0012 00 |
| Unit Repair; Tools; Special Tools; Test, Measurement, and Diagnostic Equipment (TMDE); and Support Equipment..... | 0013 00 |
| Unit Service Upon Receipt..... | 0014 00 |
| PMCS Procedures Introduction | 0015 00 |
| Unit Maintenance Procedures..... | 0016 00 |
| Tank Assembly Inspection, Repair and Replacement..... | 0017 00 |
| Clamp Assembly Inspection, Repair and Replacement..... | 0018 00 |
| Filler/Discharge Assembly Inspection, Repair and Replacement..... | 0019 00 |
| Hand Grip Assembly Inspection and Replacement..... | 0020 00 |
| Tie-down Assembly Inspection and Replacement..... | 0021 00 |
| Preparation for Storage or Shipment | 0022 00 |
| CHAPTER 6- Direct Support Maintenance Instructions | |
| Direct Support Repair; Tools; Special Tools; Test, Measurement and Diagnostic Equipment (TMDE); and Support Equipment | 0023 00 |
| Direct Support Maintenance Procedures | 0024 00 |
| Hydrostatic Test | 0025 00 |
| CHAPTER 7- Supporting Information | |
| References..... | 0026 00 |
| Maintenance Allocation Chart..... | 0027 00 |
| Repair Parts Introduction | 0028 00 |
| Repair Parts List..... | 0029 00 |
| National Stock Number Index | 0030 00 |

| | |
|---|---------|
| Part Number Index | 0031 00 |
| Components of End Item (COEI) and Basic Issue Items (BII) Lists | 0032 00 |
| Additional Authorization List..... | 0033 00 |
| Expendable and Durable Items List | 0034 00 |
| Torque Limits | 0035 00 |
| Mandatory Replacement Parts List..... | 0036 00 |

GLOSSARY

INDEX

HOW TO USE THIS MANUAL

Section I. OVERVIEW -This manual is divided into seven chapters consisting of 36 work packages that provide all the information necessary to operate and maintain the collapsible fabric water tank assemblies.

Section II. INDEXING -This manual contains several types of indexes to help the user locate information quickly and efficiently. The different indexes are as follows:

a. Table of Contents. Lists all chapters and work packages contained in the manual, along with the work package numbers where they begin.

b. Alphabetical Index. Located at the back of the manual, this index lists entries that personnel are most likely to look for. Most listings are provided several times in the index (i.e., "Maintenance Forms and Records" can also be found as "Forms and Records, Maintenance," and "Records, Maintenance Forms and"). This increases the likelihood of finding the information the first place you look. Each entry also lists the work package where the information can be found.

**OPERATOR, UNIT, AND DIRECT SUPPORT MAINTENANCE MANUAL
(INCLUDING REPAIR PARTS AND SPECIAL TOOLS LIST)
TANK, FABRIC, COLLAPSIBLE, WATER, 3,000 AND 5,000 GALLON, SEMI-TRAILER MOUNTED
GENERAL INFORMATION**

SCOPE

This technical manual contains instructions for operations, checks and corrective maintenance procedures for the 3,000 and 5,000 Gallon Collapsible Fabric Semi-Trailer Mounted Water Tanks.

Type of Manual: Operator, Unit, and Direct Support Maintenance.

Model Number and Equipment Names: PD62783-3000 and 91093 for the 3,000 gallon tanks, PD62783-4750 and 91094 for the 5,000 gallon Fabric Collapsible Potable Water Semi-Trailer Mounted Tanks.

Purpose of Equipment: The 3,000 and 5,000 gallon collapsible fabric water tanks are utilized with the M127, M871, and the M872 semi-trailers (3,000 gallon tanks), or the M872 (5,000 gallon tank), to store and distribute potable drinking water.

MAINTENANCE FORMS, RECORDS, AND REPORTS

Department of the Army forms and procedures used for equipment maintenance will be those prescribed by (as applicable) DA PAM 738-750, Functional Users Manual for The Army Maintenance Management System (TAMMS); DA PAM 738-751, Functional Users Manual for The Army Maintenance Management System Aviation (TAMMS-A); or AR 700-138, Army Logistics Readiness and Sustainability.

CORROSION PREVENTION AND CONTROL (CPC)

Corrosion Prevention and Control (CPC) of Army materiel is a continuing concern. It is important that any corrosion problems with this item be reported so that the problem can be corrected and improvements can be made to prevent the problem in future items.

While corrosion is typically associated with rusting of metals, it can also include deterioration of other materials, such as rubber and plastic. Unusual cracking, softening, swelling, or breaking of these materials may be a corrosion problem.

If a corrosion problem is identified, it can be reported using SF 368, Product Quality Deficiency Report. Use of key words such as "rust," "deterioration," "corrosion," or "cracking" will ensure that the information is identified as a CPC problem.

The form should be submitted to the address specified in DA Pam 738-750, Functional Users Manual for the Army Maintenance Management System (TAMMS).

DESTRUCTION OF ARMY MATERIEL TO PREVENT ENEMY USE

Command decisions, according to tactical situations, will determine when destruction of the collapsible fabric water tank assembly will be accomplished. A destruction plan will be prepared by the using organization, unless higher authority has prepared one. For general destruction procedures for this equipment, refer to TM 750-244-3, Procedures for Destruction of Equipment to Prevent Enemy Use.

REPORTING EQUIPMENT IMPROVEMENT RECOMMENDATIONS (EIRs)

If the collapsible fabric water tank assembly needs improvement, let us know. Send us an EIR. You, the user, are the only one who can tell us what you don't like about your equipment. Let us know why you don't like the design or performance. Put it on an SF 368 (Product Quality Deficiency Report). Mail it to us at Commander, U.S. Army Tank-automotive and Armaments Command, ATTN: AMSTA-LC-CIP-WT, Rock Island, IL 61299-7630. We will send you a reply

PREPARATION FOR STORAGE OR SHIPMENT

Refer to Work Package 0022 00.

QUALITY ASSURANCE/QUALITY CONTROL (QA/QC)

Workmanship shall be of the highest quality and shall permit no defects not repaired in accordance with the instructions in this manual. All metal parts shall be clean and free of sand, dirt, etc. The inside and outside of the tank shall be clean and free of foreign material.

END OF WORK PACKAGE

CHAPTER 1

DESCRIPTION AND THEORY OF OPERATION
FOR
TANK, FABRIC, COLLAPSIBLE, WATER, 3,000 AND 5,000 GALLONS,
SEMI-TRAILER MOUNTED

**OPERATOR, UNIT, AND DIRECT SUPPORT MAINTENANCE MANUAL
(INCLUDING REPAIR PARTS AND SPECIAL TOOLS LIST)
TANK, FABRIC, COLLAPSIBLE, 3,000 AND 5,000 GALLONS, SEMI-TRAILER MOUNTED
EQUIPMENT DESCRIPTION AND DATA**

EQUIPMENT CHARACTERISTICS, CAPABILITIES, AND FEATURES

Characteristics, capabilities, and features of the collapsible fabric semi-trailer mounted water tank assemblies include:

- a. The tank is constructed of a chlorobutyl material (a rubber coated multi-ply carcass).
- b. The tank is designed to store and transport potable water.
- c. Pull handles are provided to facilitate positioning the tank while empty.
- d. When not in use, the tank may be folded or rolled, and stored in the sling and shipping container.

DIFFERENCES BETWEEN MODELS

The models are similar except for variations in size and capacity.

LOCATION AND DESCRIPTION OF MAJOR COMPONENTS

Refer to Work Package 0004 00 for locations.

EQUIPMENT DATA

CAUTION

If the tank is used in temperatures below freezing (32°F (0°C)), caution must be used to prevent water in the tank, or in contact with metal parts, from freezing. If water freezes, damage may occur to the tank and/or metal parts.

OPERATING TEMPERATURE (AMBIENT)

LOW -25°F (-31.70°C)
HIGH 160°F (71.1°C)

STORAGE TEMPERATURE (AMBIENT)

LOW -25°F (-31.70°C)
HIGH 160°F (71.1°C)

SPECIFICATIONS, MODEL PD62783-3000

MANUFACTURER Uniroyal, Warsaw, Indiana
NSN 5430-01-181-4071
DRY DIMENSIONS 28'L X 7'4"W X 4'H (8.5m x 2.2m x 1.2m)
HEIGHT (FILLED) 54 inches (137.2cm)
WIDTH 62 inches (157.5cm)
LENGTH 27 feet (8.2m) (Approx.)
WEIGHT (Empty) 600 pounds (272.4kg) (Approx.)
CAPACITY 3,000 gallons (11,355L)

SPECIFICATIONS, MODEL 91093

MANUFACTURER Amfuel, Magnolia, Arkansas
NSN 5430-01-372-6901
DRY DIMENSIONS 28'L X 7'4"W X 4'H (8.5m x 2.2m x 1.2m)
HEIGHT (FILLED) 54 inches (137.2cm)
WIDTH 62 inches (157.5cm)

| | |
|---|--|
| LENGTH..... | 27 feet (8.2m) (Approx.) |
| WEIGHT (Empty) | 600 pounds (272.4kg) (Approx.) |
| CAPACITY | 3,000 gallons (11,355L) |
| SPECIFICATIONS, MODEL PD62783-4750 | |
| MANUFACTURER | Uniroyal, Warsaw, Indiana |
| NSN..... | 5430-01-120-7823 |
| DRY DIMENSIONS..... | 39'L X 7'4"W X 4'4"H (11.9m x 2.2m x 1.3m) |
| HEIGHT (FILLED)..... | 54 inches (137.2cm) |
| WIDTH..... | 62 inches (157.5cm) |
| LENGTH..... | 38 feet (11.6m) |
| WEIGHT (Empty) | 825 pounds (375kg) |
| CAPACITY | 4,750 gallons (17,979L) |
| SPECIFICATIONS, MODEL 91094 | |
| MANUFACTURER | Amfuel, Magnolia, Arkansas |
| NSN..... | 5430-01-372-6900 |
| DRY DIMENSIONS..... | 39'L X 7'4"W X 4'4"H (11.9m x 2.2m x 1.3m) |
| HEIGHT (FILLED)..... | 54 inches (137.2cm) |
| WIDTH..... | 62 inches (157.5cm) |
| LENGTH..... | 38 feet (11.6m) |
| WEIGHT (Empty) | 825 pounds (375kg) |
| CAPACITY | 4,600 gallons (17,411L) |

INFORMATION DATA PLATE

The following information shall be located on the tank for models 91093 and 91094:

- TORQUE 70 ± 5 IN. LBS
- DRINKING WATER
- TRANSPORT ONLY WHEN COMPLETELY FULL OR EMPTY
- REMOVE GAGE WHEN TRANSPORTING
- OPERATING PRESSURE 5 ± 1 PSIG
- TIE-DOWN STRAP LOCATIONS

The following information shall be located on the tank for models PD62783-3000 and PD62783-4750:

- TORQUE 70 ± 5 IN. LBS
- POTABLE WATER
- TRANSPORT ONLY WHEN COMPLETELY FULL OR EMPTY
- OPERATING PRESSURE 5 ± 1 PSIG
- TIE-DOWN STRAP LOCATIONS

FITTINGS

The tank is furnished with a four-inch filler/discharge assembly consisting of a male quick-disconnect, a four-inch gate valve, and a pressure gage, two 10-foot lengths of hose, and a manually operated relief valve located in the top center of the tank.

TIE-DOWN ASSEMBLY

The tie-down kit consists of four belts with eight ratchet take-up mechanisms, and trailer attachments specifically designed to minimize tank movement during transport.

EMERGENCY REPAIR ITEMS

The emergency repair kit includes temporary repair items, such as plugs and clamps, to accomplish an emergency repair.

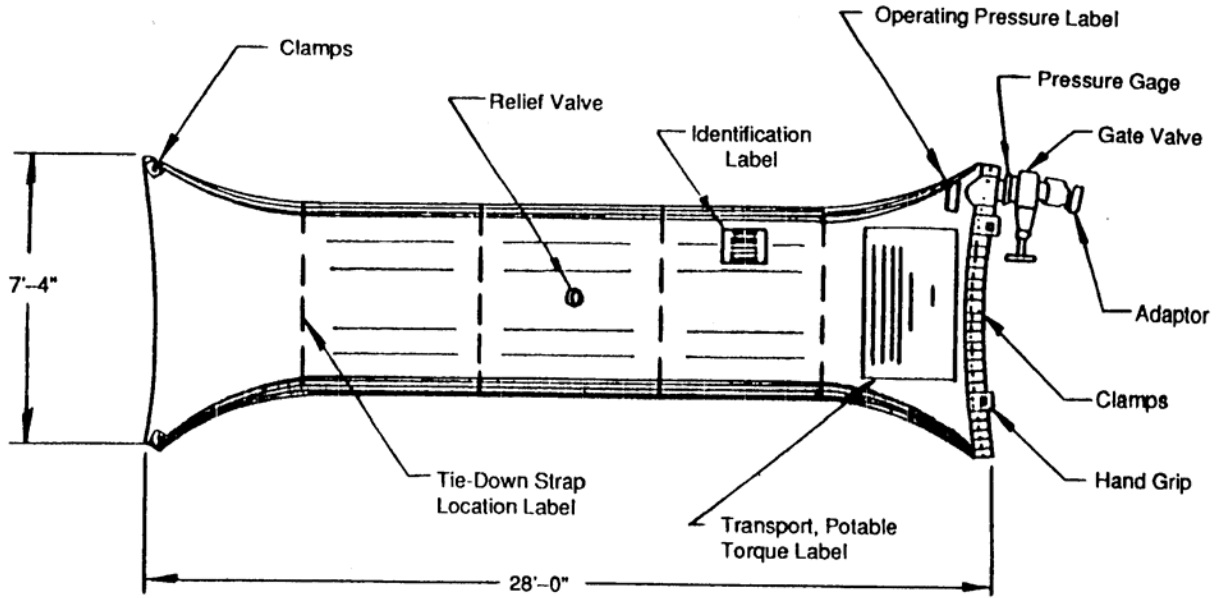

3,000 Gallon Potable Water Tank (Model PD62783-3000)

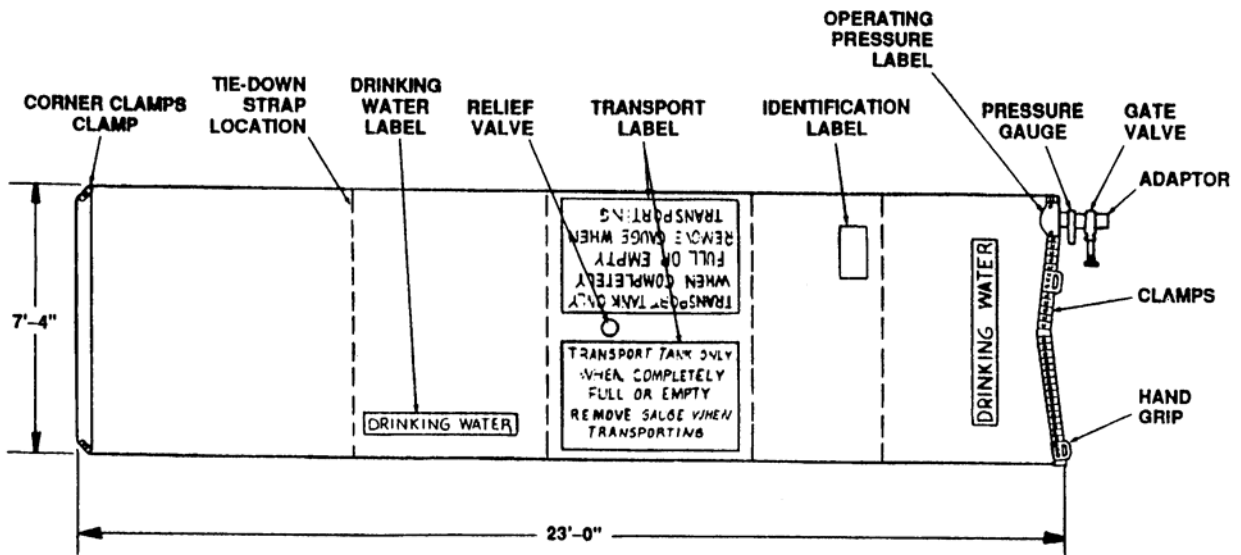

3,000 Gallon Potable Water Tank (Model 91093)

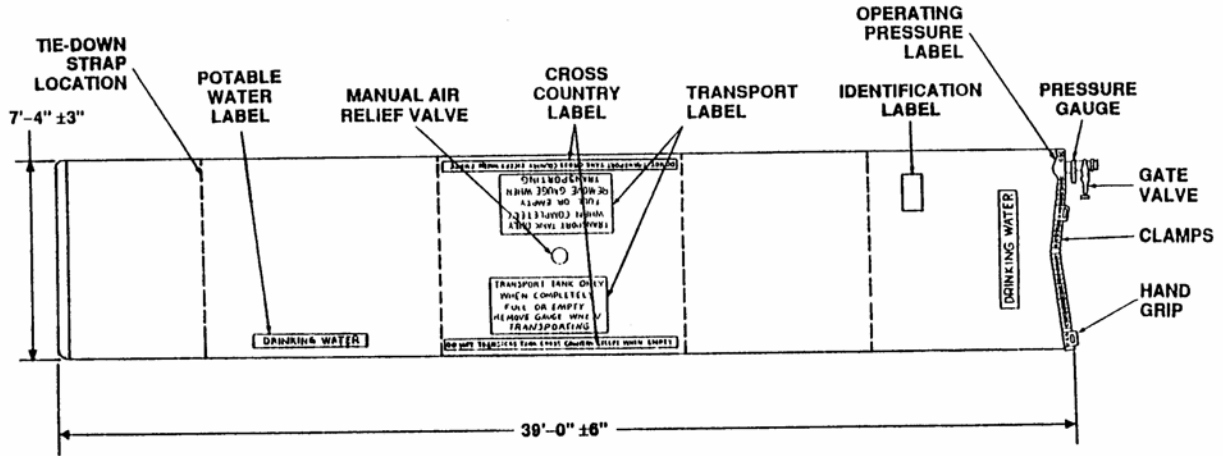

4,600 Gallon Potable Water Tank (Model 91094)
Semi-Trailer Mounted

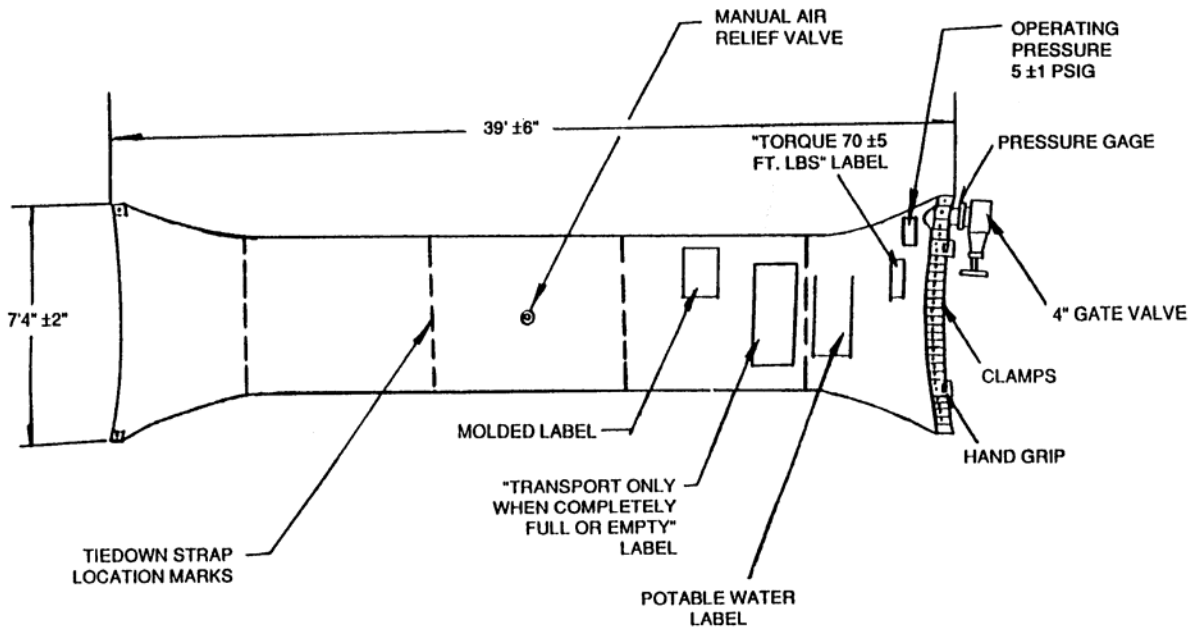

4,750 Gallon Potable Water Tank Model (PD62783-4750)
Semi-Trailer Mounted

END OF WORK PACKAGE

**OPERATOR, UNIT, AND DIRECT SUPPORT MAINTENANCE MANUAL
(INCLUDING REPAIR PARTS AND SPECIAL TOOLS LIST)
TANK, FABRIC, COLLAPSIBLE, WATER, 3,000 AND 5,000 GALLONS, SEMI-TRAILER MOUNTED
THEORY OF OPERATION**

Collapsible Water Tank Theory of Operation

The tank is used for storage and transport of potable water (drinking water).

The assembled unit consists of a collapsible tank with pressure gage, end fittings, tie-down straps, emergency repair kit items, hose and tools to secure the tank safely on the M871, M872 and M127 semi-trailers (depending on model).

Access to the tank interior is through the use of removable end clamps. When laid flat, the 3,000-gallon tank is 28 ft. long by 7 ft., 4 in. wide by 4 ft. high. When filled, the tank assumes a pillow-like shape approximately 27 ft. long by 5 ft., 2 in. wide by 4 ft., 6 in. high. The 5,000-gallon tank is 39 ft. long and 7 ft., 4 in. wide by 4 ft., 4 in. high. When filled, the tank is 38 ft. long by 5 ft., 2 in. wide by 4 ft., 6 in. high.

Handles are provided to facilitate positioning of the tank while empty. When not in use, the tank may be folded or rolled and stored in the shipping container.

END OF WORK PACKAGE

CHAPTER 2

OPERATOR INSTRUCTIONS
FOR
TANK, FABRIC, COLLAPSIBLE, WATER, 3,000 AND 5,000 GALLONS,
SEMI-TRAILER MOUNTED

**OPERATOR, UNIT AND DIRECT SUPPORT MAINTENANCE MANUAL
(INCLUDING REPAIR PARTS AND SPECIAL TOOLS LIST)
TANK, FABRIC, COLLAPSIBLE, WATER, 3,000 AND 5,000 GALLONS, SEMI-TRAILER MOUNTED,
DESCRIPTION AND USE OF OPERATOR CONTROLS AND INDICATORS**

GENERAL

This section lists major components, controls, and indicators, and describes the functions within the collapsible fabric water tank assemblies.

DESCRIPTION AND USE OF MAJOR COMPONENTS

Typical illustrations are below. Descriptions and use of major components, including controls and indicators, are listed in Table 1.

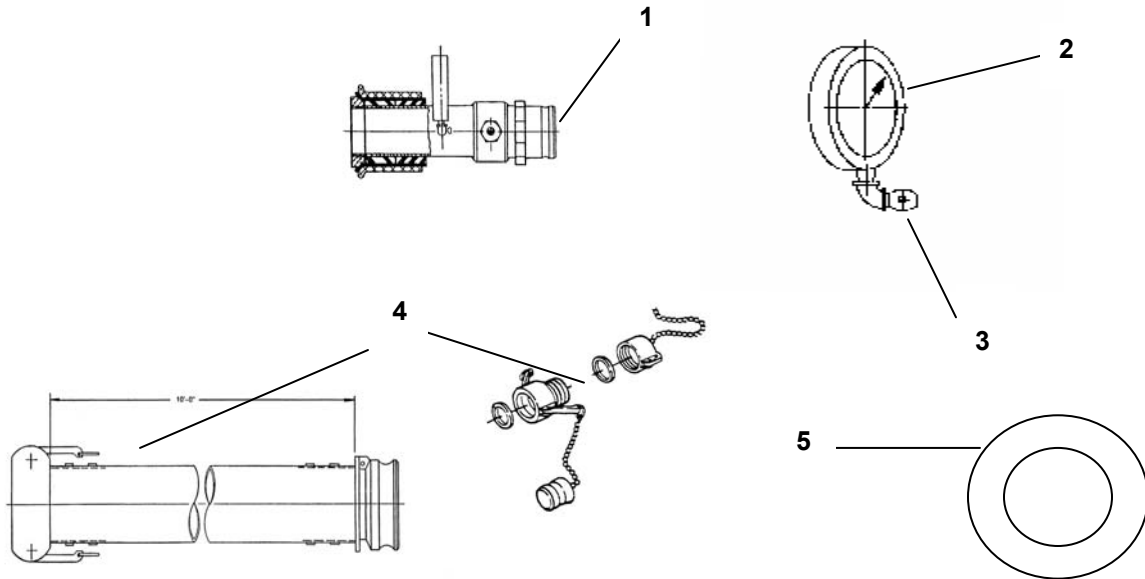

Table 1. Major Components, Controls and Indicators.

| Key | Control or Indicator | Function |
|-----|------------------------|---|
| 1 | Filler/Discharge Valve | The filler/discharge valve is a 4-inch gate valve, which, together with the hose assembly, provides the connection necessary to both fill and empty the tank. |
| 2 | Pressure Gage | A 0 - 15 PSI pressure gage is supplied to monitor the pressure of the filled tank. Operating pressure is 4 - 6 PSI. |
| 3 | Pressure Gage Valve | The pressure gage is controlled by a .25 NPT valve. The valve needs to be closed when the pressure gage is removed. |
| 4 | Hose Assembly | The hose assembly consists of two, 10-foot long by 4-inch diameter water hoses with quick disconnect fittings, dust caps and plugs. |
| 5 | Pressure Relief Valve | Located on the top of the tank, the pressure relief valve is manually operated to relieve trapped air. It is opened and closed with finger pressure. |

END OF WORK PACKAGE

**OPERATOR, UNIT AND DIRECT SUPPORT MAINTENANCE MANUAL
(INCLUDING REPAIR PARTS AND SPECIAL TOOLS LIST)
TANK, FABRIC, COLLAPSIBLE, WATER, 3,000 AND 5,000 GALLONS, SEMI-TRAILER MOUNTED
OPERATION UNDER USUAL CONDITIONS**

ASSEMBLY AND PREPARATION FOR USE

Unpacking the Equipment

1. When a new or used tank (1) is received, it must be uncrated.
2. Unload the crate (2) as near to its point of installation as possible.
3. Remove the nails from the crate top (3) and remove the top.

CAUTION

Remove all protruding nails and other objects prior to attempting to remove the tank from the container. This is essential in order to avoid puncturing the tank.

4. Using a suitable lifting device, attach to the lift straps (4) of the sling (5), and carefully lift tank (1) out of the crate (2), and transport the tank (1) to the designated point of installation.
5. The repair items (6) are in a box at the end of crate (2). The tie down assembly and pressure gage are packaged in the duffle bag (7). These items should be placed in a secure place until needed.

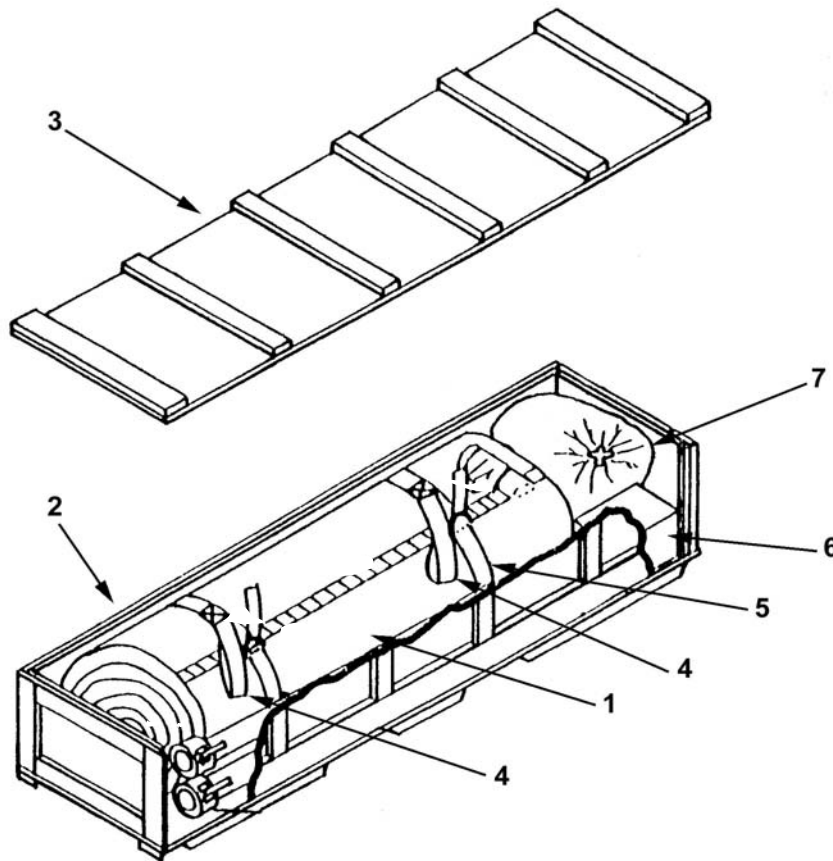

Typical Crating Models PD62783-3000 and 91093

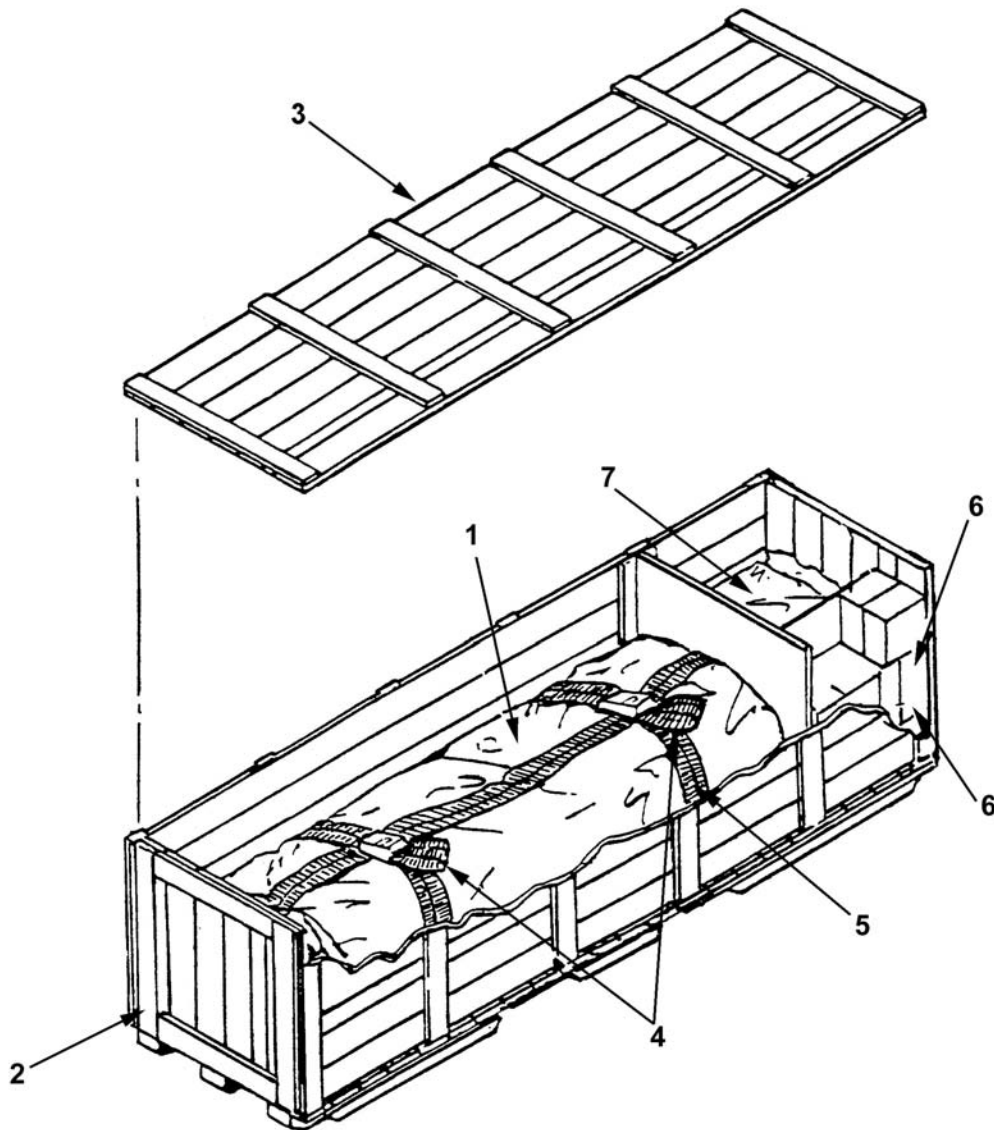

Typical Crating for Models PD62783-4750 and 91094

Installation of the Tie-Down Kit

1. The tank is to be installed on the flatbed of the M871, M872 or M127 semi trailer for the 3,000-gallon tank models. The 5,000-gallon models are to be installed on the M872 semi-trailer only.

CAUTION

Clear the semi-trailer area of sticks, stones, heavy vegetation or any debris that may puncture or cause abrasions to the tank fabric.

2. Clear the semi-trailer bed of splinters, protruding nails and other foreign objects that could puncture or chafe the tank.
3. Place the bed cloth (Models 91093 and 91094) on the truck bed forward and unroll to the rear.

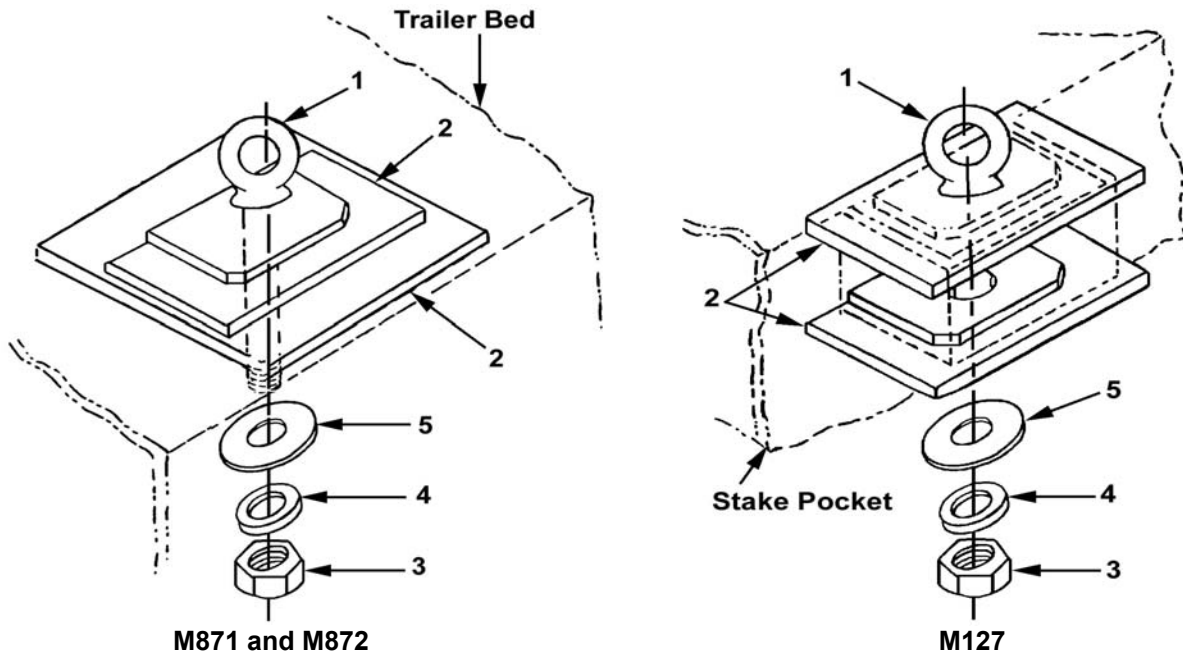

Anchor Assembly (M871 and M872 Trailer Bed and M127 Stake Pocket)

4. The tank is secured to the trailer with a four-belt tie-down kit. There are two anchor points per belt to provide maximum support to the tank during transport. Each anchor point consists of a 5/8" diameter eyebolt (1), two retaining plates (2), one 5/8" hex nut (3), one lock washer (4), and one flat washer (5) used on Models 91093, 91094 and PD62783-3000 only.
5. Determine the strap locations as shown and install the anchor assembly. On Models PD62783-3000 and PD62783-4750, recheck the area for sharp objects. If the surface is rough and jagged, it will be necessary to place plywood or a tarpaulin down for the tank to rest upon.
6. Attach the ratchet take-up mechanism (6) to each anchor point by using a shackle (7) between the eyebolt (1) and delta ring (8) on the ratchet take-up mechanism (6).
7. Lay the tie-down straps (9) crosswise to the length of the semi-trailer bed. Make sure straps (9) are centered accurately between the eyebolts (1). Let the remaining portion of straps (9) lay over the sides of the trailer. Straps (9) should be lying flat and not twisted. The area is now prepared for tank unfolding.

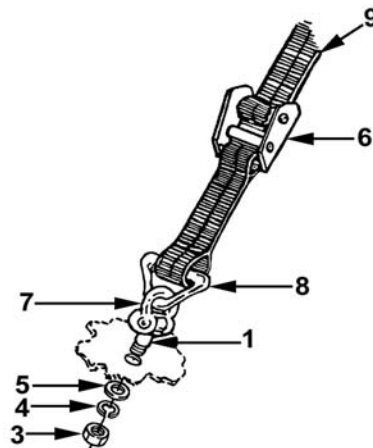

Tie-Down Assembly

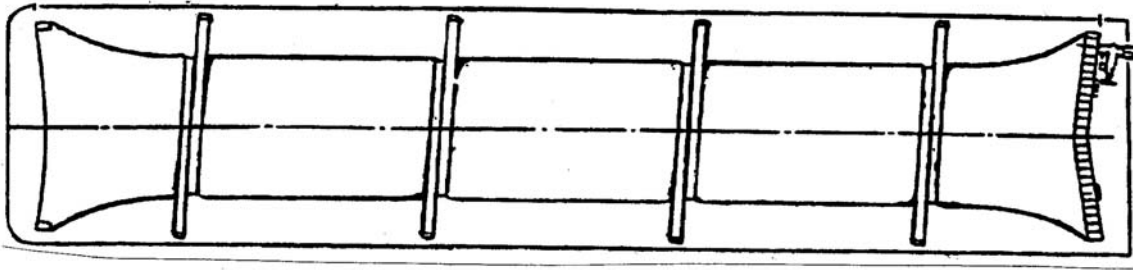

NOTE

Use holes in trailer bed to attach anchors and straps at the approximate locations shown. Straps may need to be repositioned later.

Belt Locations (M872 Trailer) (5,000 Gallon Models)

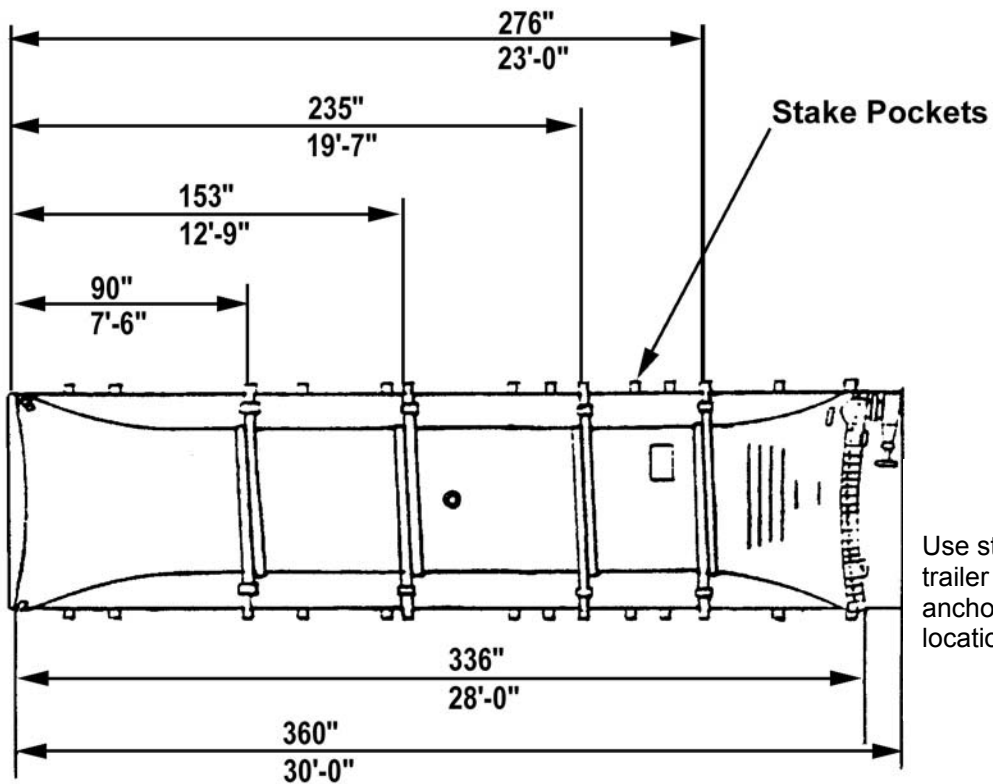

NOTE

Use stake pockets on trailer bed to attach anchors and straps at locations shown.

Belt Locations (M127 Trailer) (3,000 Gallon Models)

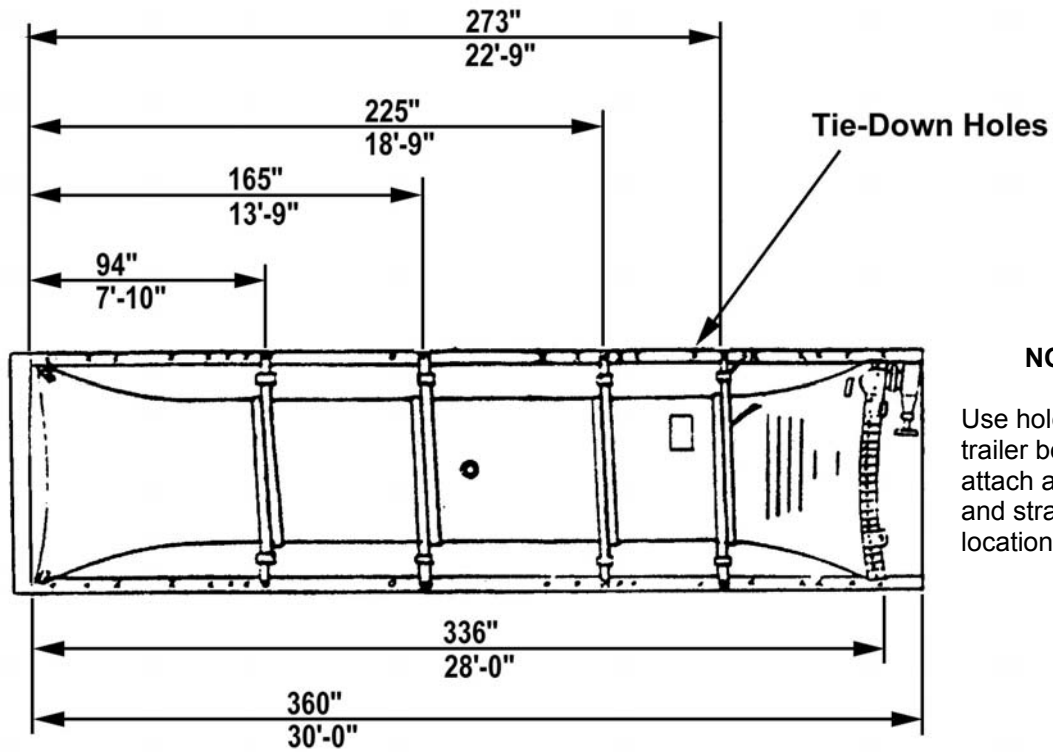

NOTE

Use holes in trailer bed to attach anchors and straps at locations shown.

Belt Locations (M871 Trailer) (3,000 Gallon Models)

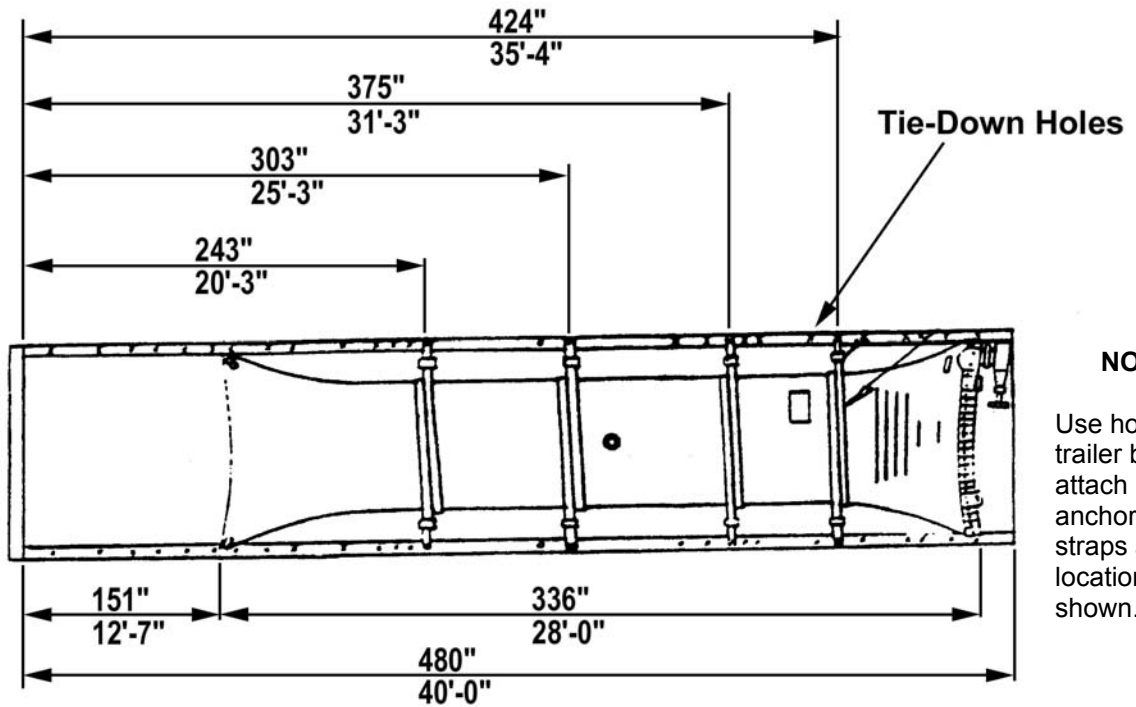

NOTE

Use holes in trailer bed to attach anchors and straps at locations shown.

Belt Locations (M872 Trailer) (3,000 Gallon Models)

Installation of the Tank on the Trailer Bed

CAUTION

Do not attach handles to a mechanical pulling device or damage to the tank will occur. Only walk on tank wearing soft soled shoes wiped clean of all abrasive materials.

1. Using a suitable lifting device, carefully attach to the sling by the lift straps and place the tank on the semi-trailer in such a manner that the tank will unroll towards the rear of the trailer. The tank ends should be near or touching the trailer bulkhead.
2. Remove the straps from the buckles on the sling assembly, unroll and unfold the tank over the tie-down straps. Visually inspect the tank while unrolling. Position the tank so that when it is full, the ends of the sidewalls will not rub against the forward bulkhead or hang over the sides of the trailer. Remove the sling assembly from under the tank and place it in the trailer storage compartment.
3. Inspect the tank body for any punctures or tears. Inspect the fittings and components for evidence of damage or missing bolts or gaskets.

Correction of deficiencies

Correct deficiencies found during the initial inspection as follows:

- a. Deficiencies within the scope of unit maintenance should be corrected before the tank is placed into service. Tears or punctures in the tank walls may be temporarily repaired by following the instructions in WP 0006 00.
- b. Serious deficiencies, or deficiencies beyond the scope of this manual, should be brought to the attention of your supervisor. Do not attempt unauthorized repairs.

OPERATING INSTRUCTIONS ON DECALS AND INSTRUCTION PLATES

Instruction plates are used on the 3,000 gallon and 5,000 gallon tanks to advise the operator of proper operating procedures. Stencils provide additional operating information and cautions to be observed during use of equipment. The following illustrations show the typical decals provided on the collapsible fabric water tanks, and identify their location on the unit.

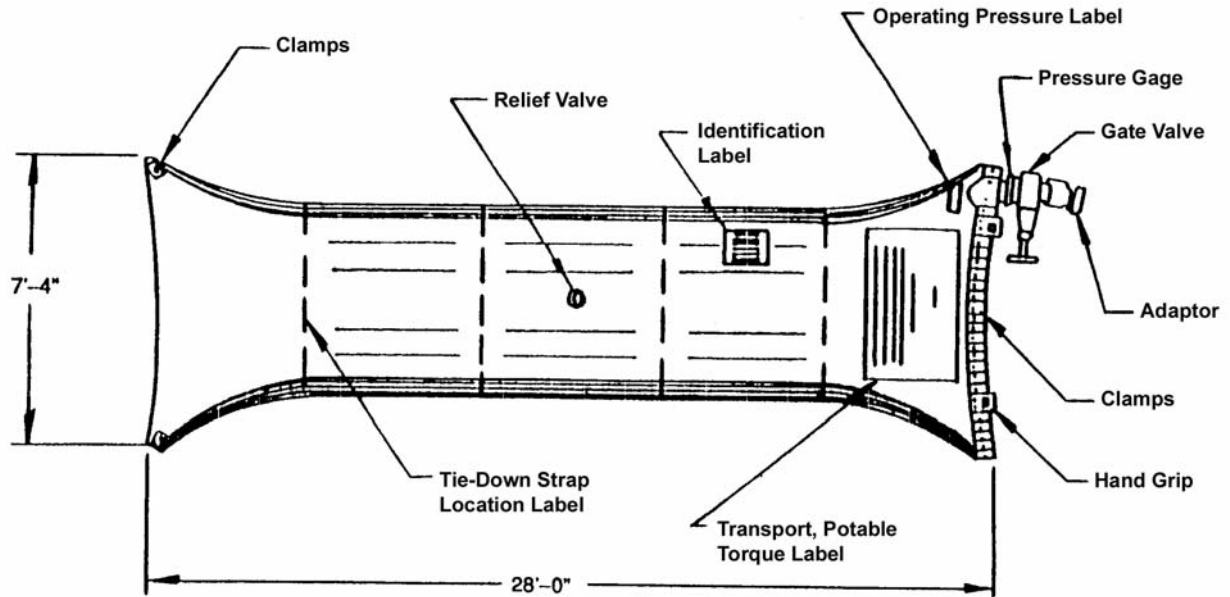

3,000 Gallon Potable Water Tank (Model PD62783-3000)

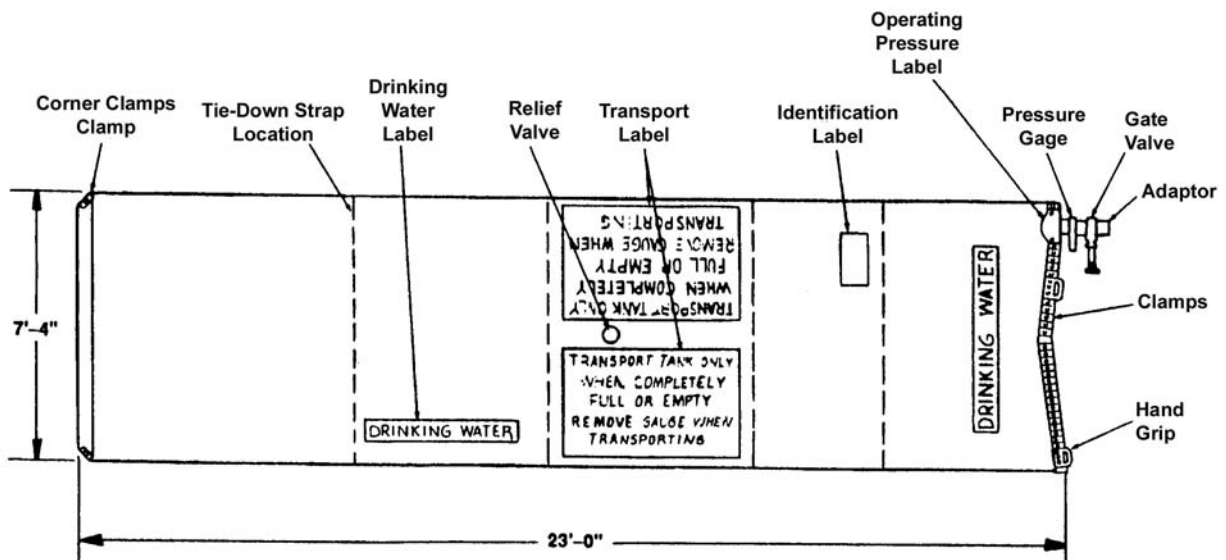

3,000 Gallon Potable Water Tank (Model 91093)

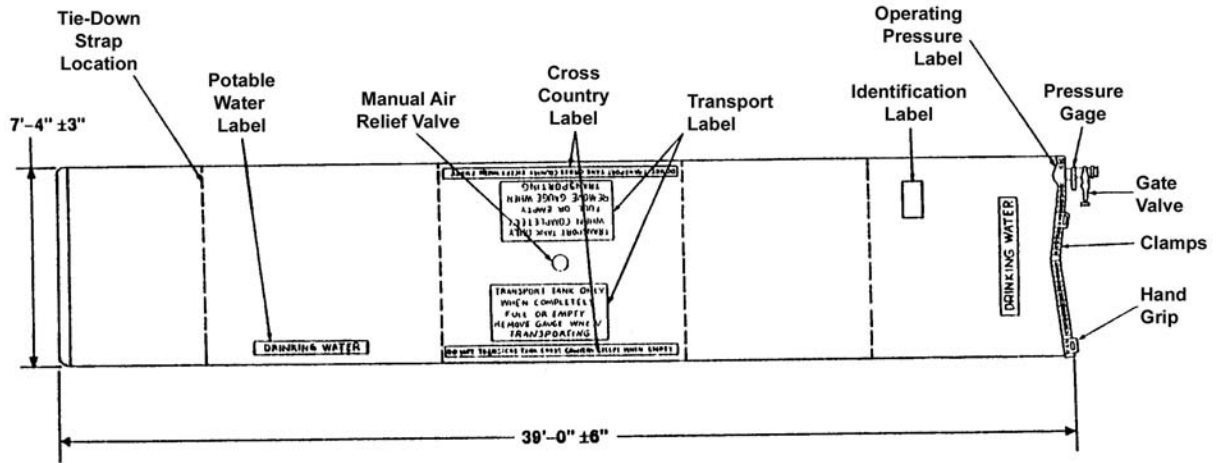

**4,600 Gallon Potable Water Tank (Model 91094)
Semi-Trailer Mounted**

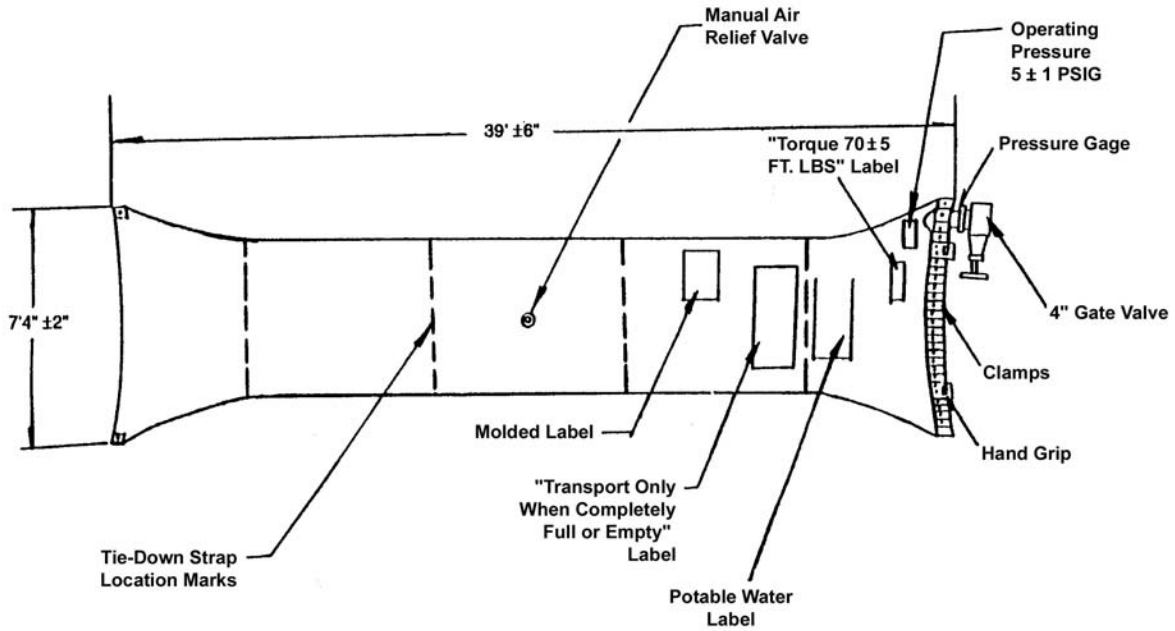

**4,750 Gallon Potable Water Tank (Model PD62783-4750)
Semi-Trailer Mounted**

OPERATING PROCEDURES (Filling the Tank)

1. Verify the tank is properly installed. The trailer bed should be level to prevent the tank from rolling.
2. Tighten all cap screws on the end clamps to 70.0 ± 5.0 ft-lbs (95 ± 7 N•m). The rubbers in the new tank will “cold flow” under the pressure and the torque will drop. The tanks should be retightened to the specifications periodically until the rubber has set and the torque does not drop appreciably. If leakage is noted at the fittings or if the tank is subjected to hard usage, the cap screws should be checked and retightened periodically.
3. Attach the pressure gage (1) to the filler/discharge valve (2). Open the pressure gage valve (3).

NOTE

Before using the tank for the first time or after prolonged storage, flush the tank with 100 - 300 gallons of clean disinfectant and water solution. The solution consists of .5 gallons of bleach mixed in 250 gallons of fresh water. Surge the cleansing solution by walking back and forth on the tank or by rocking the truck with abrupt starts and stops. The resultant surge will clean the collapsed tank without exposing the interior to contaminants or foreign objects. Rinse the tank with 250 gallons of clean water to remove the bleach taste. When the cleaning is complete, close the tank valve immediately to hermetically seal out contaminants.

4. Before starting to fill the tank, be sure that all air has been expelled, then close the 4-inch tank inlet valve.
5. Attach a water source to the supplied 4-inch diameter hose. Purge the air from the filling line and the hose by opening the valve at the water source until the water comes out of the supplied hose. Turn off the water at the water source.
6. The free ends of the hold down belts should now be brought over the top of the tank and down the other side through the ratchet-take-up mechanism attached to the trailer bed. Slide the ends of the belts two feet through the slot in the ratchet assembly. Fold the end back on belt and hold manually until one turn has been taken up on the roll-up spool.
7. Attach the hose to the tank filler/discharge valve (2).
8. Open the valve at the potable water supply.
9. Open the filler/discharge valve (2) on the tank.
10. No pressure will show on the pressure gage (1) until the tank is approximately two feet high. From that point on, periodically check the exact tank pressure by closing the 4-inch filler/discharge valve (2) on the tank to obtain a precise tank pressure reading.
11. After the pressure reading has been taken, open the 4-inch filler/discharge valve (2) on the tank and resume filling to 2-3 PSIG (14-21 kPa).
12. Open the relief valve on the top of the tank until water flows from the valve.
13. Tighten the belts with the ratchet handle then tighten the belts to maximum possible with one hand on the ratchet handle. The second hand should be used to steady the ratchet assembly so that the belt will wind flat and true. After tightening each ratchet assembly, see that the ratchet handle has dropped securely into the locking mechanism. When all ratchet assemblies have been tightened uniformly, the pressure in the tank will be increased approximately .25 PSI (2 kPa).

NOTE

If tank ends are not level with the trailer floor, the tank may be leveled by releasing the ratchet on one side of the tank, and then taking up the slack by tightening the opposite ratchet.

14. After filling the tank to the correct pressure (4-6 PSI) (21-41 kPa), shut off the filling hose valve first, then shut off the tank filler/discharge valve (2). Some loss of water between the valves will be experienced at this point. Material is under pressure between the valves. Low pressure will be created if the filling hose valve is shut off first as directed above, high-pressure if the tank valve is shut off first.

NOTE

The closed system of filling a tank allows the pressure to build up very rapidly as the tank reaches full capacity. It is recommended that tank containers be filled to a final minimum pressure of 4 PSI (21 kPa) and a maximum of 6 PSI (41 kPa).

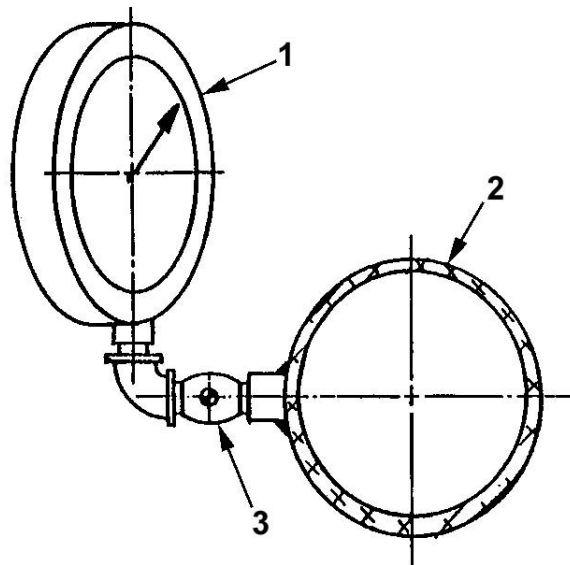

Pressure Gage Assembly

15. Keep the pressure gage valve (3) open to allow continual observation of the tank pressure.

WARNING

The tank must be transported only when completely full or completely empty, or injury to personnel could result.

16. The tank is now properly filled and secured for transportation. Regular periodic checks for tight belts is recommended. Belts should be tightened at least every two hours.

DRAINING THE TANK

WARNING

The tank can only be emptied by gravity or suction pump. Use of air pressure to unload the tank is not authorized as it may cause the tank to burst under pressure and cause injury to personnel.

Draining by Gravity

1. The end of the tank opposite the valve must be 8 to 10 inches higher than the valve end of the tank to thoroughly complete draining of the tank. The valve corner should be the lowest level of the tank. Use the grade elevation or portable ramps under the appropriate trailer wheels.
2. Connect one end of the 4-inch diameter hose assembly to the tank filler/discharge valve.
3. Connect the other end of the hose to the hose or container requiring the potable water.
4. Close the tank pressure gage valve.
5. Open the filler/discharge valve on the tank to start the flow.
6. After the operation is complete, close the filler/discharge valve on the end of the tank.

Draining by Pump

1. Connect one end of the 4-inch diameter hose assembly to the tank filler/discharge valve.
2. Connect the other end of the hose to the hose from the pump.
3. Close the tank pressure gage valve.
4. Open the tank filler/discharge valve.
5. Start the pump. Draining rate is not a factor in tank operations.
6. After operation is complete, close the tank filler/discharge valve.
7. Close the valve on the pump.
8. Disconnect the 4-inch diameter hose assembly from the hose container or vacuum pump, depending on applicability.
9. Disconnect the hose from the tank filler/discharge valve.

REPACKING

CAUTION

Make sure the tank is completely dry before folding. Water will create mildew, decreasing the life of the tank if it is not completely dry.

1. Remove the pressure gage (1).
2. Disconnect hold-down kit ratchets (2) and remove. Hang loose ends of the belts over the sides of the trailer.

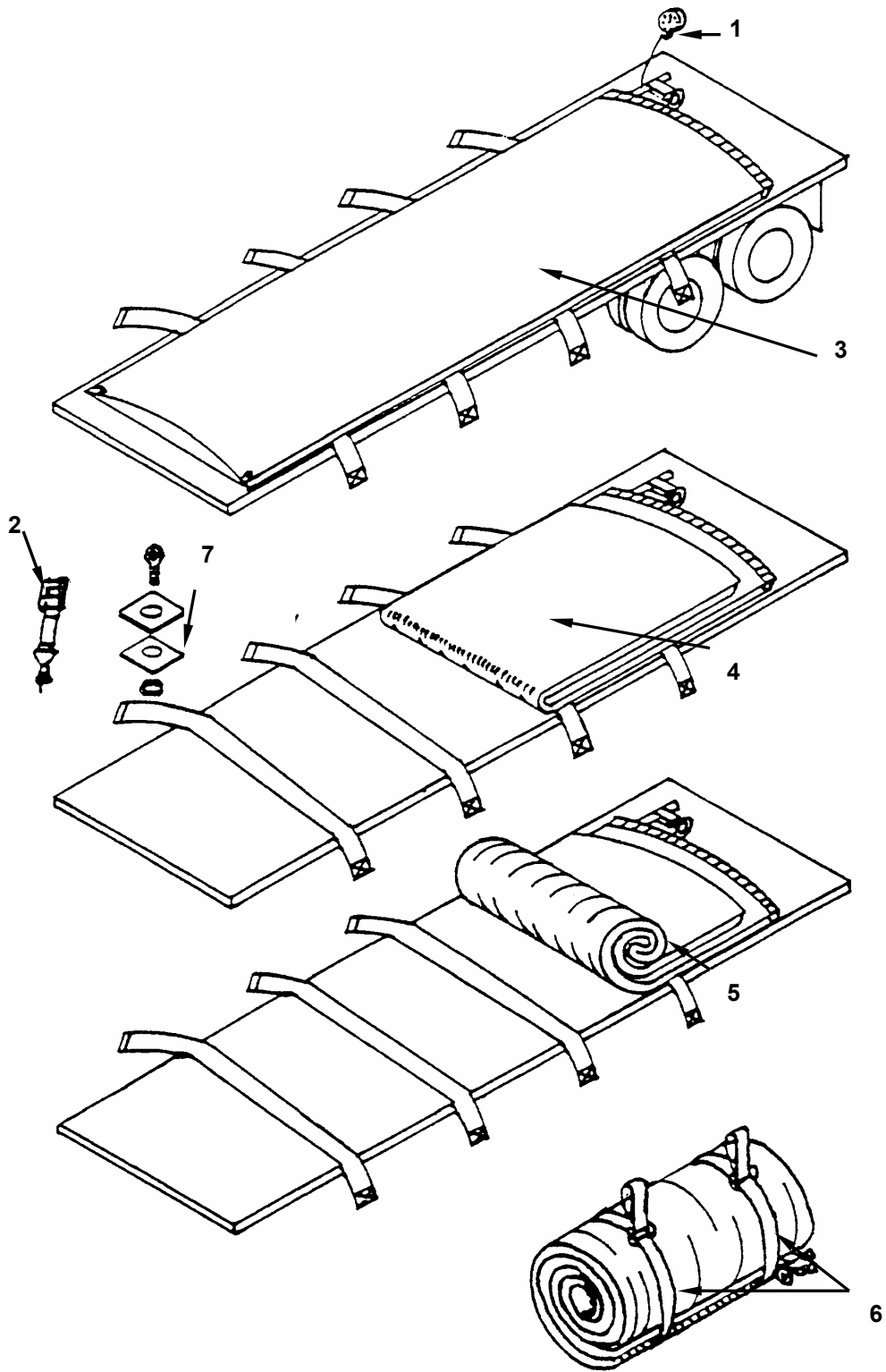

3. Fold the tank (3) almost in half lengthwise (4). Lay top fold of the tank down approximately 1 foot shorter than the bottom fold. The ends will then be equal when the tank is rolled.
4. Roll the tank (5) manually. It is necessary that the first roll be circular and tight, otherwise the tank will be hard to roll and make a large package.

CAUTION

Throughout the folding process, be sure to brush off any stones, grass, or other debris that may accumulate on the tank or the ground cloth. Accumulation of debris can cause damage to the tank.

5. The sling (6) may be slipped around and under the tank if the tank is to be transported to a new location or placed back in its shipping container. The sling (6) is located in the semi-trailer stowage compartment. Fold the trailer bed cloth (Models 91093 and 91094).
6. Remove and store the hold down kit ratchets (2) and the anchor bolt assembly (7) in the prepared area. Pad the pressure gage (1) to avoid damage.
7. After the first few uses, the tank will become more flexible and easier to roll and unroll.

PREPARATION FOR MOVEMENT

WARNING

The tank must be transported only when completely full or completely empty or injury to personnel could result.

1. When the tank is full, before movement, the tank should be lashed to the trailer with the sling provided.
2. When the tank is empty, before movement, the tank should be rolled up and lashed securely to the trailer.
3. When the tank is not in use, unit assemblies and components should be disassembled, dried, cleaned and preserved for future use.

END OF WORK PACKAGE

**OPERATOR, UNIT AND DIRECT SUPPORT MAINTENANCE MANUAL
(INCLUDING REPAIR PARTS AND SPECIAL TOOLS LIST)
TANK, FABRIC, COLLAPSIBLE, WATER, 3,000 AND 5,000 GALLONS, SEMI-TRAILER MOUNTED
OPERATION UNDER UNUSUAL CONDITIONS**

OPERATION IN EXTREME HEAT

Observe the following precautions when operating the water tank in extreme heat:

1. Protect tank from extreme heat by covering, setting up in a shaded area or by constructing a sun block.
2. Do not block airflow. Ventilate area around the tank.
3. Avoid unnecessary folding or unfolding of the empty water tank.

OPERATION IN EXTREME COLD

CAUTIONS

If the tank is used in temperatures below freezing [32°F (0°C)], caution must be used to prevent water in the tank, or in contact with the fluid discharge fittings, from freezing. If water freezes, damage may occur to the tank and/or fittings.

Avoid any unnecessary handling of the tank, which might cause cracking or damage to the material.

1. Do not allow ice to accumulate on the tank or the filler/discharge fittings.
2. Keep snow and ice clear of the relief valve assembly.

OPERATION IN SALT WATER AREAS

Clean the filler/discharge fittings with clean water prior to filling or drawing water from the tank.

OPERATION IN SANDY OR DUSTY AREAS

1. Keep all components clean. Keep plugs and caps in place on fittings until ready to use.
2. Cover all components when not in use.

OPERATION AT HIGH ALTITUDES

No special procedures are required for operation at high altitudes.

OPERATION IN MUD

Ensure that the filler/discharge fittings are clean before filling or drawing water from the tank.

OPERATION IN HIGH WIND

Keep the tank as full of drinking water as possible.

OPERATION IN RAIN

If possible, provide adequate drainage ditches to prevent standing pools of water around the tank.

EMERGENCY PROCEDURES

TYPE I EMERGENCY REPAIRS

When holes in water tank are less than 2 inches (5.08cm), repairs will be as follows:

Water Tank Filled

1. When necessary, insert a wood plug (1) into hole (2) of tank (3) to temporarily stop the leak. Select size of plug required:

| <u>Hole Size</u> | <u>Plug</u> |
|---------------------------------|--------------------|
| Up to 3/8 inch (.95cm) | 5/8 inch (1.59cm) |
| 3/8 to 1 inch (.95 to 2.54cm) | 1 1/2 inch (3.8cm) |
| 1 to 1 1/2 inch (2.54 to 3.8cm) | 2 inch (5.08cm) |

2. Push small end of wood plug (1) into hole (2). Turn wood plug (1) until tight. Leak in tank (3) should slow down, and then stop as wood plug is tightened.
3. Continue the mission. Check wood plug (1) during operation. If repair begins to leak, tighten wood plug again.
4. When mission is complete, replace wood plug (1) with mechanical patch.

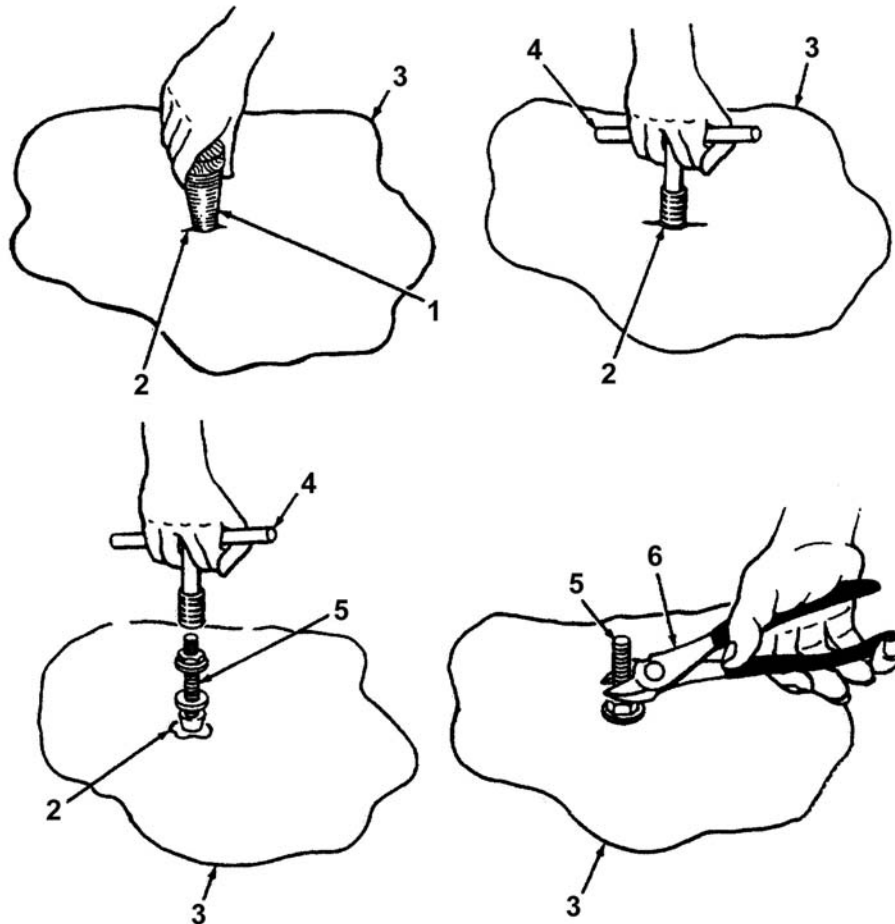

Water Tank Empty

1. Remove wood plug (1) from hole (2) in tank (3).
2. Use rotary cutter (4) to remove damaged fabric from tank (3) and prepare hole (2) for mechanical patch (5).
3. Select correct size of mechanical patch (5) required.

| <u>Hole Size</u> | <u>Patch</u> |
|----------------------------------|-------------------|
| Up to 3/8 inch (.95cm) | 3/4 inch (1.91cm) |
| 3/8 to 1 1/2 inch (.95 to 3.8cm) | 2 inch (5.08cm) |

4. Screw mechanical patch (5) into end of rotary cutter (4).
5. Push cone shaped end of mechanical patch (5) through prepared hole (2) and pull tight to inside of tank (3) container wall.
6. Screw aluminum cap of mechanical patch (5) and rotary cutter (4) handle down tight. Use socket end of rotary cutter (4) to tighten cap.
7. Cut off excess shank of mechanical patch (5) with pliers (6).
8. If hole (2) is too large to be repaired with mechanical patch (5), notify unit maintenance.

TYPE II EMERGENCY REPAIRS

When holes in the water tank are more than 2 inches (5.08cm), repairs will be as follows:

Water Tank Empty

NOTE

The repair kit supplied with the water tank contains mechanical patches that can be used for repairs to the tank fabric. These can be used to seal punctures, slits or tears up to 6 inches (15.24cm) in size.

1. Select correct size of mechanical patch required:

| <u>Hole Size</u> | <u>Mechanical Patch</u> |
|--------------------------------------|-------------------------|
| Up to 1 7/8 inch (4.76cm) | 3 inch (7.62cm) |
| 1 7/8 to 3 7/8 inch (4.76 to 9.84cm) | 5 inch (12.7cm) |
| 3 7/8 to 6 inch (9.84 to 15.24cm) | 7 1/2 inch (19.05cm) |

2. Insert bottom plate (1) through hole (2) in tank (3). Use a knife to enlarge hole (2) if clamp bottom plate (1) will not fit through hole. Enlarge hole equally on both sides.
3. Rotate clamp bolt (4) on bottom plate (1) 1/4 turn or as required to center bottom plate (1) under hole (2). Pull and hold lanyard (5) to keep top plate (6) centered.
4. Slide top plate (6) and wing nut (7) down onto threaded portion of clamp bolt (4). Position top plate (6) directly over bottom plate (1).

5. Tighten wing nut (7) with pliers (8) until tank (3) fabric is securely clamped and leak has stopped.
6. If hole is too large to be repaired with mechanical patch, replace tank.

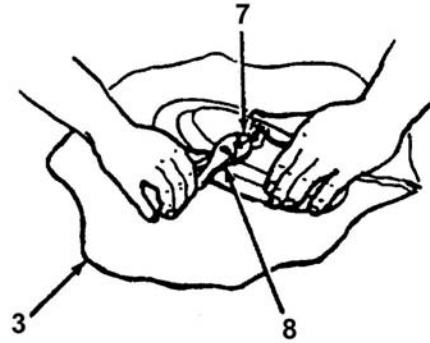
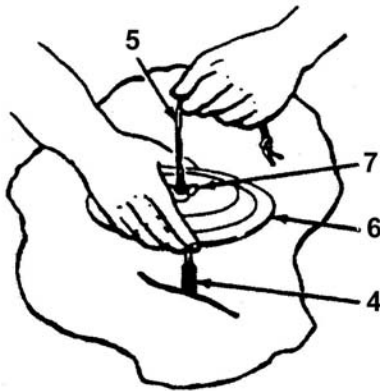
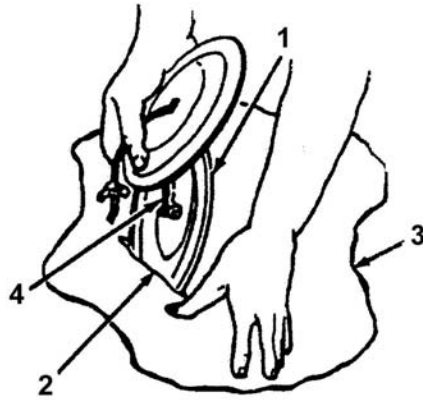

INTERIM NUCLEAR, BIOLOGICAL, AND CHEMICAL (NBC) DECONTAMINATION PROCEDURES**NOTE**

Detailed decontamination procedures can be found in: FM 3-3, FM 3-4, and FM 3-5.

General

The following emergency procedures can be performed until field NBC decontamination facilities are available.

Emergency Procedures**WARNING**

If NBC attack is known or suspected, mask at once and continue mission. Do not remove your mask until told to do so. Removing the mask could cause injury or death.

1. Nuclear decontamination - Brush fallout from skin, clothing, and equipment with available brushes, rags, and tree branches. Wash skin and have radiation check made as soon as tactical situation permits.
2. Biological decontamination - Remain masked and continue mission until told to unmask.
3. Chemical detection and decontamination.

WARNING

Do not use decontamination spray on personnel. It could cause personal injury.

- a. Use M8 paper from the M256 chemical agent detector kit or M9 paper to determine if liquid agent is present on the surface of the equipment.
- b. If exposure to liquid agent is known or suspected, clean the exposed skin, clothing, and personal gear, in that order, using M258A1 kit. Use the buddy system. Wash exposed skin and thoroughly decontaminate as soon as tactical situation permits.
- c. If the M8 or M9 paper indicates that liquid chemical agent is present, rinse the exposed portion of the collapsible tank with a liberal amount of water. When the tactical situation permits, wash the collapsible tank with soapy water, and rinse thoroughly.
- d. Decontamination procedures take time. Do as much as you can, depending on the tactical situation.

END OF WORK PACKAGE

CHAPTER 3
TROUBLESHOOTING PROCEDURES
FOR
TANK, FABRIC, COLLAPSIBLE, WATER, 3,000 AND 5,000
GALLONS, SEMI-TRAILER MOUNTED

**OPERATOR, UNIT AND DIRECT SUPPORT MAINTENANCE MANUAL
(INCLUDING REPAIR PARTS AND SPECIAL TOOLS LIST)
TANK, FABRIC, COLLAPSIBLE, WATER, 3,000 AND 5,000 GALLONS, SEMI-TRAILER MOUNTED
OPERATOR TROUBLESHOOTING PROCEDURES**

INTRODUCTION TO OPERATOR TROUBLESHOOTING

The Troubleshooting Procedures list the common malfunctions that you may find during the operation or maintenance of the collapsible fabric water tank assembly or its components. Perform the tests/inspections and corrective actions in the order listed in the table.

This manual cannot list all malfunctions that may occur, nor all tests or inspections and corrective actions. If a malfunction is not listed or is not corrected by listed corrective actions, notify your supervisor.

WARNING

Water must be drained from the tank before attempting to replace components, or injury to personnel could result.

TROUBLESHOOTING PROCEDURE

TANK

SYMPTOM

Tank leaks.

MALFUNCTION

Check the water tank for cuts, tears, or punctures.

CORRECTIVE ACTION

Perform emergency repairs using wood plugs or sealing clamps (WP 0006 00). If the leak cannot be repaired, notify unit maintenance.

TROUBLESHOOTING PROCEDURE

FILLER/DISCHARGE VALVE ASSEMBLY

SYMPTOM

Tank body leaks at pipe clamp.

MALFUNCTION

Check for loose or missing bolts on clamping plate.

CORRECTIVE ACTION

Notify unit maintenance.

SYMPTOM

Quick disconnect adapter is loose.

MALFUNCTION

Check for tightness.

CORRECTIVE ACTION

Notify unit maintenance.

Check the dust cap gaskets for distortion or wear.

CORRECTIVE ACTION

Notify unit maintenance.

TROUBLESHOOTING PROCEDURE

END FITTING ASSEMBLY

SYMPTOM

Tank leaks at clamping points.

MALFUNCTION

Check for loose or missing bolts on the clamps.

CORRECTIVE ACTION

Notify unit maintenance.

Check for damaged clamps.

CORRECTIVE ACTION

Notify unit maintenance.

TROUBLESHOOTING PROCEDURE

PRESSURE GAGE

SYMPTOM

Pressure gage fails to operate.

MALFUNCTION

Check for bent indicator or broken air cock.

CORRECTIVE ACTION

Notify unit maintenance.

TROUBLESHOOTING PROCEDURE

TIE-DOWN ASSEMBLY

SYMPTOM

Ratchet take-up mechanism fails to operate.

MALFUNCTION

Check for broken or damaged take-up components.

CORRECTIVE ACTION

Replace strap.

TROUBLESHOOTING PROCEDURE

PRESSURE RELIEF VALVE

SYMPTOM

Pressure relief valve leaks.

MALFUNCTION

Check for loose valve nut.

CORRECTIVE ACTION

Notify unit maintenance.

END OF WORK PACKAGE

**OPERATOR, UNIT AND DIRECT SUPPORT MAINTENANCE MANUAL
(INCLUDING REPAIR PARTS AND SPECIAL TOOLS LIST)
TANK, FABRIC, COLLAPSIBLE, WATER, 3,000 AND 5,000 GALLONS, SEMI-TRAILER MOUNTED
UNIT TROUBLESHOOTING PROCEDURES**

INTRODUCTION TO UNIT TROUBLESHOOTING

The Troubleshooting Procedures list the common malfunctions that you may find during the operation or maintenance of the collapsible fabric water tank assembly or its components. Perform the tests/inspections and corrective actions in the order listed in the table.

This manual cannot list all malfunctions that may occur, nor all tests or inspections and corrective actions. If a malfunction is not listed or is not corrected by listed corrective actions, notify your supervisor.

WARNING

Water must be drained from the tank before attempting to replace components, or injury to personnel could result.

TROUBLESHOOTING PROCEDURE

TANK

SYMPTOM

Tank leaks.

MALFUNCTION

Check the water tank for cuts, tears, or punctures.

CORRECTIVE ACTION

Install patch (WP 0017 00). If the leak cannot be repaired, replace the tank.

TROUBLESHOOTING PROCEDURE

FILLER/DISCHARGE VALVE ASSEMBLY

SYMPTOM

Tank body leaks at pipe clamp.

MALFUNCTION

Check for loose or missing bolts on clamping plate.

CORRECTIVE ACTION

Tighten bolts to 70 ± 5 ft-lbs (95 ± 7 N • m)

SYMPTOM

Quick disconnect adapter is loose.

MALFUNCTION

Check quick disconnect adapter for looseness

CORRECTIVE ACTION

Tighten the quick disconnect adapter.

Check quick disconnect elbow gaskets for distortion or wear.

CORRECTIVE ACTION

Remove the elbow and replace the gaskets.

Check the dust cap gaskets for distortion or wear.

CORRECTIVE ACTION

Remove the dust cap and replace the gaskets.

TROUBLESHOOTING PROCEDURE

END FITTING ASSEMBLY

SYMPTOM

Tank leaks at clamping points.

MALFUNCTION

Check for loose or missing bolts on the clamps.

CORRECTIVE ACTION

Tighten all clamping bolts to 70 ± 5 ft-lbs (95 ± 7 N • m).

Check for damaged clamps.

CORRECTIVE ACTION

Replace the top and/or bottom clamps (WP 0018 00).

TROUBLESHOOTING PROCEDURE

PRESSURE GAGE

SYMPTOM

Pressure gage fails to operate.

MALFUNCTION

Check for bent indicator or broken air cock.

CORRECTIVE ACTION

Remove the gage, and physically blow air into the end of the gage.

Replace pressure gage if necessary (WP 0019 00).

TROUBLESHOOTING PROCEDURE

TIE-DOWN ASSEMBLY

SYMPTOM

Ratchet take-up mechanism fails to operate.

MALFUNCTION

Check for broken or damaged take-up components.

CORRECTIVE ACTION

Replace broken or damaged take-up parts as necessary.

TROUBLESHOOTING PROCEDURE

PRESSURE RELIEF VALVE

SYMPTOM

Pressure relief valve leaks.

MALFUNCTION

Check for loose valve nut.

CORRECTIVE ACTION

Tighten valve nut to 30 ft-lbs (41 N • m).
Hand tighten plug finger-tight.

END OF WORK PACKAGE

**OPERATOR, UNIT AND DIRECT SUPPORT MAINTENANCE MANUAL
(INCLUDING REPAIR PARTS SPECIAL TOOLS LIST)
TANK, FABRIC, COLLAPSIBLE, WATER, 3,000 AND 5,000 GALLONS, SEMI-TRAILER MOUNTED
DIRECT SUPPORT TROUBLESHOOTING PROCEDURES**

DIRECT SUPPORT TROUBLESHOOTING PROCEDURES

No troubleshooting is authorized at Direct Support Maintenance.

END OF WORK PACKAGE

CHAPTER 4

OPERATOR MAINTENANCE INSTRUCTIONS
FOR
TANK, FABRIC, COLLAPSIBLE, WATER, 3,000 AND 5,000 GALLONS,
SEMI-TRAILER MOUNTED

**OPERATOR, UNIT AND DIRECT SUPPORT MAINTENANCE MANUAL
(INCLUDING REPAIR PARTS AND SPECIAL TOOLS LIST)
TANK, FABRIC, COLLAPSIBLE, WATER, 3,000 AND 5,000 GALLONS, SEMI-TRAILER MOUNTED
PMCS PROCEDURES INTRODUCTION**

INTRODUCTION

General

Preventive Maintenance Checks and Services (PMCS) are performed to keep the trailer mounted collapsible fabric water tank assembly in operating condition. The checks are used to find, correct or report problems. Be sure to perform your PMCS each time you service the tank assembly. Using the PMCS table, always do PMCS in the same order, so it gets to be a habit. With practice, you will quickly detect problems. Pay attention to WARNING and CAUTION statements. A WARNING means someone could be hurt. A CAUTION means the equipment could be damaged.

Before you use the tank assembly, do "Before" PMCS.

During use, do "During" PMCS.

After the tank assembly is used, do "After" PMCS.

If you find something wrong when performing PMCS, fix it if you can, using troubleshooting procedures and/or maintenance procedures.

Use DA Form 2404 (Equipment Inspection and Maintenance Worksheet) to record any faults that you discover before, during, or after operation, unless you can fix them. You do not need to record faults that you fix. For further information on how to use this form, see DA PAM 738-750.

Operator PMCS Procedures

Your Preventive Maintenance Checks and Services, Table 1, lists the inspections and care required to keep the water tank assembly in good operating order.

The "Interval" column of Table 1 tells you when to do a certain check or service.

The "Procedure" column of Table 1 tells you how to do the required checks and services. Carefully follow these instructions. When the procedure tells you to, notify your supervisor.

"Equipment Not Ready/Available If" column tells you when and why your equipment cannot be used.

Leakage Definitions

| | |
|-----------|---|
| Class I | Seepage of water (as indicated by wetness or discoloration) not great enough to form drops. |
| Class II | Leakage of water great enough to form drops but not enough to cause the drops to drip or run from the faulty area. |
| Class III | Leaks of water great enough to form drops that fall or run or collect in puddles near the faulty area. |
| Class IV | Leakage found under the tank. There is evidence of dampness on the trailer bed cloth or on the ground. Volume of water in tank is less than it should be. |

CAUTIONS

Equipment operation is allowed with a minor leak, (Class I or II). When operating with Class I or II leaks, continue to check visually and at regular intervals. Class III or IV leaks should be repaired as soon as the equipment can be taken out of service.

Stop operation immediately if a deficiency is noticed which would damage the equipment if operation continued.

NOTE

Within the designated interval, these checks are to be performed in the order listed.

Table 1. Operator Preventive Maintenance Checks and Services for the 3,000 and 5,000 Gallon Semi-Trailer Mounted Collapsible Water Tanks.

| ITEM NO. | INTERVAL | MAN-HOUR | ITEM TO BE CHECKED OR SERVICED | PROCEDURE | EQUIPMENT NOT READY/ AVAILABLE IF: |
|----------|----------|----------|---------------------------------------|--|---|
| 1 | Before | | Installation Area | Inspect the semi-trailer to prevent the accumulation of stones, sticks, and other sharp objects that might cause punctures and/or leaks. | Sharp objects that can cause damage to the tank have not been cleared away. |
| 2 | Before | | Water Tank/Envelope | Inspect for cuts, punctures and leaks. Bolts are loose or missing where fittings connect to tank. | Tank envelope is cut, punctured or leaks. Fitting bolts are loose or missing. |
| 3 | Before | | Bed Cloth (Models 91093 & 91094 only) | Inspect for damage. | Bed cloth is damaged. |
| 4 | Before | | Filler/Discharge Assembly | Inspect for proper connection, evidence of damage or leakage. | Connection is damaged, leaking or loose. |
| 5 | During | | Installation Area | Inspect the semi-trailer to prevent the accumulation of stones, sticks, and other sharp objects that might cause punctures and leaks. | Sharp objects that can cause damage to the tank have not been cleared away. |
| 6 | During | | Water Tank/Envelope | Inspect for cuts, punctures and leaks. Bolts are loose or missing where fittings connect to tank. | Tank envelope is cut, punctured or leaks. Fitting bolts are loose or missing. |

Table 1. Operator Preventative Maintenance Checks and Services for the 3,000 and 5,000 Gallon Semi-Trailer Mounted Collapsible Water Tanks (continued).

| ITEM NO. | INTERVAL | MAN-HOUR | ITEM TO BE CHECKED OR SERVICED | PROCEDURE | EQUIPMENT NOT READY/ AVAILABLE IF: |
|----------|----------|----------|---------------------------------------|---|---|
| 7 | During | | Filler/Discharge Assembly | Inspect for proper connection, evidence of damage or leakage. | Connection is damaged, leaking or loose. |
| 8 | After | | Bed Cloth (Models 91093 & 91094 only) | Inspect for damage. | Bed cloth is damaged. |
| 9 | After | | Water Tank/Envelope | Inspect for cuts, punctures and leaks. Bolts loose or missing where fittings connect to tank. | Tank envelope is cut, punctured or leaks. Fitting bolts loose or missing. |
| 10 | After | | Filler/Discharge Assembly | Inspect for proper connection, evidence of damage or leakage. | Connection is damaged, leaking or loose. |

END OF WORK PACKAGE

**OPERATOR, UNIT AND DIRECT SUPPORT MAINTENANCE MANUAL
(INCLUDING REPAIR PARTS AND SPECIAL TOOLS LIST)
TANK, FABRIC, COLLAPSIBLE, WATER, 3,000 AND 5,000 GALLONS, SEMI-TRAILER MOUNTED
OPERATOR MAINTENANCE PROCEDURES**

GENERAL INSTRUCTIONS

Operator maintenance is limited to the replacement of damaged or missing gaskets on all quick disconnect couplings and to performing emergency tank repairs using wood plugs and sealing clamps (WP 0006 00).

END OF WORK PACKAGE

CHAPTER 5

UNIT MAINTENANCE INSTRUCTIONS
FOR
TANK, FABRIC, COLLAPSIBLE, WATER, 3,000 AND 5,000 GALLONS,
SEMI-TRAILER MOUNTED

**OPERATOR, UNIT AND DIRECT SUPPORT MAINTENANCE MANUAL
(INCLUDING REPAIR PARTS SPECIAL TOOLS LIST)
TANK, FABRIC, COLLAPSIBLE, WATER, 3,000 AND 5,000 GALLONS, SEMI-TRAILER MOUNTED
LUBRICATION INSTRUCTIONS**

LUBRICATION INSTRUCTIONS

Lubrication not required.

END OF WORK PACKAGE

**OPERATOR, UNIT AND DIRECT SUPPORT MAINTENANCE MANUAL
(INCLUDING REPAIR PARTS SPECIAL TOOLS LIST)
TANK, FABRIC, COLLAPSIBLE, WATER, 3,000 AND 5,000 GALLONS, SEMI-TRAILER MOUNTED
UNIT REPAIR; TOOLS; SPECIAL TOOLS; TEST, MEASUREMENT
AND DIAGNOSTIC EQUIPMENT (TMDE); AND SUPPORT EQUIPMENT**

COMMON TOOLS AND EQUIPMENT

For authorized common tools and equipment refer to the Modified Table of Organization and Equipment (MTOE) applicable to the unit.

SPECIAL TOOLS, TMDE AND SUPPORT EQUIPMENT

No special tools or TMDE are required for operation or maintenance of the 3,000 and 5,000 collapsible fabric semi-trailer mounted water tanks.

REPAIR PARTS

Repair parts are listed and illustrated in WP 0029 00 of this manual.

END OF WORK PACKAGE

**OPERATOR, UNIT AND DIRECT SUPPORT MAINTENANCE MANUAL
(INCLUDING REPAIR PARTS SPECIAL TOOLS LIST)
TANK, FABRIC, COLLAPSIBLE, WATER, 3,000 AND 5,000 GALLONS, SEMI-TRAILER MOUNTED
UNIT SERVICE UPON RECEIPT**

SERVICE UPON RECEIPT OF MATERIEL

Inspect the equipment for damage (punctures or tears) incurred during shipment. If the equipment has been damaged, report the damage in accordance with the instructions of DA PAM 738-750.

Check the equipment against the packing slip to see if the shipment is complete. Report all discrepancies in accordance with the instructions of DA PAM 738-750.

The tank will be shipped in a crate. Unload it as near to its point of installation as possible.

The repair items are in a box at the end of the crate. These items should be stored in a secure place until needed. The tie-down assembly and pressure gauge are packaged in the duffle bag.

Check to see if the equipment has been modified.

INSTALLATION INSTRUCTIONS

The 3,000-gallon tanks are to be installed on the M871, M872, or M127 semi-trailers. The 5,000-gallon tanks utilize the M872 only.

PRELIMINARY SERVICING AND ADJUSTMENT OF EQUIPMENT

No preliminary servicing or adjustment is required.

CAUTION

Remove all protruding nails and other objects prior to attempting to remove the tank from the container or damage to the tank could occur.

A suitable lifting device, such as a forklift, is necessary to lift the tank from its crate. Use the lift straps and sling to uncrate.

END OF WORK PACKAGE

**OPERATOR, UNIT AND DIRECT SUPPORT MAINTENANCE MANUAL
(INCLUDING REPAIR PARTS SPECIAL TOOLS LIST)
TANK, FABRIC, COLLAPSIBLE, WATER, 3,000 AND 5,000 GALLONS, SEMI-TRAILER MOUNTED,
PMCS PROCEDURES INTRODUCTION**

INTRODUCTION**General**

Preventive Maintenance Checks and Services (PMCS) are performed to keep the trailer mounted collapsible fabric water tank assembly in operating condition. The checks are used to find, correct or report problems. Be sure to perform your PMCS each time you service the tank assembly. Using the PMCS table, always do PMCS in the same order, so it gets to be a habit. With practice, you will quickly detect problems. Pay attention to WARNING and CAUTION statements. A WARNING means someone could be hurt. A CAUTION means the equipment could be damaged.

Before you use the tank assembly, do "Before" PMCS.

During use, do "During" PMCS.

After the tank assembly is used, do "After" PMCS.

Do "Weekly" PMCS once a week.

Do "Quarterly" PMCS once every three months.

If you find something wrong when performing PMCS, fix it if you can, using troubleshooting procedures and/or maintenance procedures.

Use DA Form 2404 (Equipment Inspection and Maintenance Worksheet) to record any faults that you discover before, during, or after operation, unless you can fix them. You do not need to record faults that you fix. For further information on how to use this form, see DA PAM 738-750.

Unit PMCS Procedures

Your Preventive Maintenance Checks and Services, Table 1, lists the inspections and care required to keep the water tank assembly in good operating order.

The "Interval" column of Table 1 tells you when to do a certain check or service.

The "Procedure" column of Table 1 tells you how to do the required checks and services. Carefully follow these instructions. When the procedure tells you to, notify your supervisor.

"Equipment Not Ready/Available If" column tells you when and why your equipment cannot be used.

Leakage Definitions

| | |
|-----------|--|
| Class I | Seepage of water (as indicated by wetness or discoloration) not great enough to form drops. |
| Class II | Leakage of water great enough to form drops but not enough to cause the drops to drip or run from the faulty area. |
| Class III | Leakage of water great enough to form drops that fall or run or collect in puddles near the faulty area. |

Class IV

Leakage under the tank. There is evidence of dampness on the trailer bed cloth or on the ground. Volume of water in tank is less than it should be.

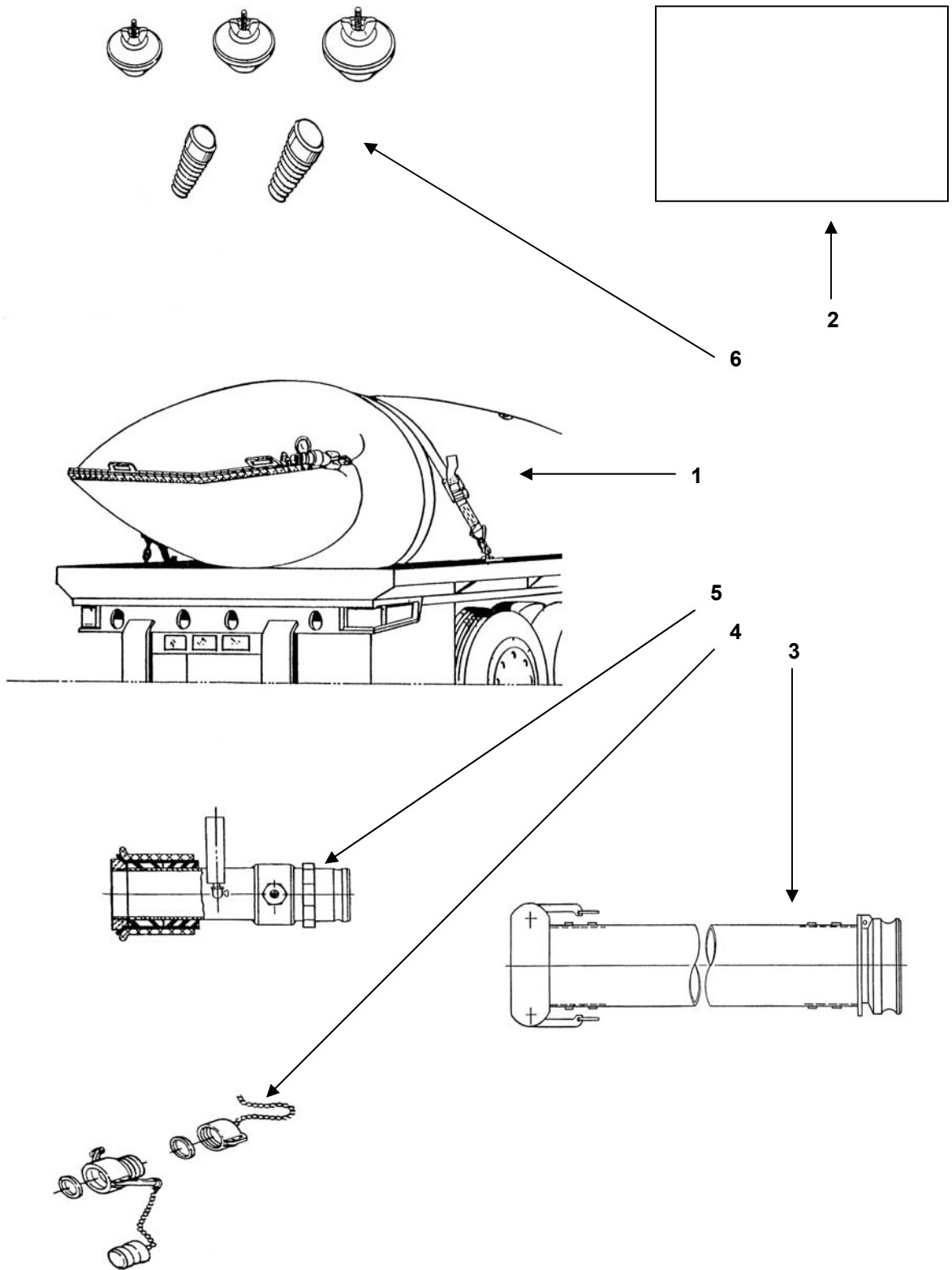

CAUTIONS

Equipment operation is allowed with a minor leak, (Class I or II). When operating with Class I or II leaks, continue to check visually and at regular intervals. Class III and IV leaks should be repaired as soon as the equipment can be taken out of service.

Stop operation immediately if a deficiency is noticed which would damage the equipment if operations continued.

NOTE

Within the designated interval, these checks are to be performed in the order listed.

Table 1. Unit Preventive Maintenance Checks and Services for 3,000 and 5,000 Gallon Semi-Trailer Mounted Collapsible Water Tanks.

| ITEM NO. | INTERVAL | MAN-HOUR | ITEM TO BE CHECKED OR SERVICED | PROCEDURE | EQUIPMENT NOT READY/ AVAILABLE IF: |
|----------|-----------|----------|---|---|--|
| 1 | Quarterly | | Water Tank/Envelope | Inspect for cuts, punctures and leaks. Check for loose or missing bolts where fittings connect to tank. | Tank envelope is cut, punctured or leaks. Fitting bolts loose or missing. |
| 2 | Quarterly | | Ground Cloth | Inspect for punctures or tears. | Ground cloth is damaged. |
| 3 | Quarterly | | Drain Assembly/Hose Attachments | Inspect for missing gaskets or damaged coupling arms. Check for leaks. | Gaskets missing or damaged coupling arms. Class III leaks present. |
| 4 | Quarterly | | Filler/Discharge Couplings and Hose Attachments | Inspect for proper connection, leakage, and loose or missing gaskets. | Couplings are damaged or loose. Hose fittings straining fabric. Class III leaks present. |
| 5 | Quarterly | | Gate Valve | Check for proper operation and/or leakage. | Gate valve will not open/close. Class III leaks present. |
| 6 | Quarterly | | Repair Kit | Check for missing components. | Repair items are missing. |

END OF WORK PACKAGE

**OPERATOR, UNIT AND DIRECT SUPPORT MAINTENANCE MANUAL
(INCLUDING REPAIR PARTS AND SPECIAL TOOLS LIST)
TANK, FABRIC, COLLAPSIBLE, WATER, 3,000 AND 5,000 GALLONS, SEMI-TRAILER MOUNTED
UNIT MAINTENANCE PROCEDURES**

GENERAL INSTRUCTIONS

Unit maintenance instructions in this section will list: resources required, personnel required and equipment condition for start of procedure, except as noted below:

- Personnel required are listed only if the task requires more than one person.
- The normal standard equipment condition to start a maintenance task is with the water tank drained and deflated.

EQUIPMENT**MAINTENANCE PROCEDURE**

| | |
|-------------------------------------|------------|
| Tank Assembly | WP 0017 00 |
| Clamp Assembly | WP 0018 00 |
| Filler/Discharge Assembly | WP 0019 00 |
| Hand Grip Assembly | WP 0020 00 |
| Tie-Down Assembly | WP 0021 00 |
| Preparation For Storage Or Shipment | WP 0022 00 |

END OF WORK PACKAGE

**OPERATOR, UNIT AND DIRECT SUPPORT MAINTENANCE MANUAL
(INCLUDING REPAIR PARTS SPECIAL TOOLS LIST)
TANK ASSEMBLY
INSPECTION, REPAIR AND REPLACEMENT**

INITIAL SETUP**Tools**

Tool Kit, General Mechanic
(Item 1, WP 0027 00)
Shop Equipment, Automotive
(Item 2, WP 0027 00)

Materials/Parts

Repair Kit
(Item 1, WP 0034 00)

Tank Assembly

This procedure consists of patching cuts and punctures in the tank fabric. If the tank must be put back in immediate service, or materials are not available, perform emergency repairs instead of this task.

There are three methods to repair water holding tank fabric.

- Preferred Method: Patches are used on both the inside and outside of the tank.
- First Alternate: Single patch on the inside of the tank.
- Second Alternate: Single patch on the outside of the tank.

Fabric that does not hold water needs only one exterior patch.

1. Ensure all components of the repair kit (ROCTAD) are present:

Table 1. Collapsible Fabric and Drums Repair Components.

| DESCRIPTION | ITEM No. | QUANTITY |
|--------------------------------------|----------|----------|
| Coated Fabric Patches (18X18 Inches) | 1 | 2 |
| Scuffing Brush | 2 | 1 |
| Q.D. Surface Conditioner | 3 | 2 Cans |
| D&A Fluid Elastomer Base | 4 | 2 Cans |
| D&A Fluid Elastomer Solidifier | 5 | 2 Cans |
| Mixing Stirrer | 6 | 1 |
| Protective Gloves, Disposable | 7 | 2 Pair |
| Synthetic Brush, Bristle, 1 In wide | 8 | 3 |
| Cleaning and Solvent Cloth | 9 | 1 |
| Cleaner/Degreaser | 10 | 1 Can |
| Spatula, Application | 11 | 2 |
| Protective Sheets | 12 | 1 |
| Respirator Mask | 13 | 2 |
| Instructions | 14 | 1 |
| Material Safety Data Sheets | 15 | 2 Sets |
| Reusable Bag | 16 | 1 |
| Razor Knife | 17 | 1 |
| Mixing Bowl | 18 | 2 |

2. Provide a smooth, firm surface under the tank fabric to be repaired. Position the protective sheet (Item 12, Table 1) between the area to be repaired and the adjacent tank fabric to prevent the fabric from sticking together
3. Use repair patches (Item 1, Table 1) in a size required to overlap at least 2.0 inches (5.1 cm) on all sides.
4. If two patches are required to cover the hole, make sure the second patch overlaps the first patch by 2.0 inches (5.1 cm).

WARNING

The cleaning fluids and adhesives in the repair kit are flammable and toxic to the skin, eyes, and respiratory tract. Skin and eye protection are required. Avoid prolonged breathing of vapors, and minimize skin contact. Protective gloves and respirator masks are part of the repair kit. Good general ventilation is normally adequate.

Keep away from excessive heat, open flames, or other sources of ignition. Do not eat, drink, or smoke while using these chemicals.

Do not use the cleaner/degreaser near aluminum fittings on the tank. Contact of the cleaner/degreaser to aluminum can cause explosive gases to form. These gases can cause further damage to the tank or injury to personnel.

NOTE

Degreasing tank fabric can result in processing oils and waxes being drawn to the fabric surface. This impairs adhesion of the fluid elastomer (adhesive) to the tank fabric. The tank fabric should be tested for compatibility with the cleaner/degreaser.

5. Test the cleaner/degreaser (Item 10, Table 1) on a small area of the tank fabric.
 - (1) Moisten the cleaning cloth (Item 9, Table 1) with a small amount of cleaner/degreaser (Item 10, Table 1).
 - (2) Rub on a small area of the tank. If a greasy film appears, skip to step 7. Otherwise go to step 6.
6. Clean the entire area of the tank to be patched with cleaner/degreaser (Item 10, Table 1).
7. Undercut fine edges of the hole with the razor knife (Item 17, Table 1). Scuff the mating surfaces of both the tank and patches with the scuffing brush (Item 2, Table 1). The roughened area on the tank should extend approximately 1.0 inch (2.5 cm) on all sides beyond the surface where the patch will be installed.
8. Brush away loose contamination and degrease again if needed.

NOTE

A can of surface conditioner should cover approximately 6.5 sq. ft. (0.63 sq. meters).

9. All mixing and application tools should be cleaned immediately after use with cleaner/degreaser (Item 10, Table 1).
10. Immediately brush a thin, even coat of surface conditioner (Item 3, Table 1) onto the area of the tank to be patched. Use the brush (Item 8, Table 1) as a stipple to ensure the thinnest possible film.

NOTE

The touch dry time will be dependent on the ambient temperature and relative humidity. The touch dry time at 68°F (20°C) and 50% relative humidity will be 20 to 30 minutes. Overcoating of surface conditioner with fluid elastomer must take place within 4.0 hours.

11. Let surface conditioner (Item 3, Table 1) set until touch dry before overcoating with mixed fluid elastomer. Test by lightly touching one knuckle down into surface conditioner (Item 3, Table 1). Lift slowly. If no conditioner is left on knuckle, it is dry. If a second (outside) patch is to be applied, repeat steps 7 through 11 for outside of the tank before going onto step 12.

NOTE

Both the base and solidifier components of the fluid elastomer must remain sealed until just before application. For best results, do not apply the mixed adhesive under the following conditions:

- a. The temperature is below 41°F (5°C).
 - b. The relative humidity is above 90%.
 - c. During rain, snow, fog, or mist.
 - d. There is moisture on the tank surface or moisture is likely to condense on the tank before the adhesive cures.
 - e. The working environment is likely to be contaminated by oil or grease from adjacent equipment, or smoke from kerosene heaters or tobacco smoke.
12. Empty entire contents of one can of the fluid elastomer base (Item 4, Table 1) into the mixing bowl (Item 18, Table 1).
 13. Shake one can of the fluid elastomer solidifier (Item 5, Table 1). Pour the contents over the elastomer base (Item 4, Table 1) in the mixing bowl (Item 18, Table 1).
 14. Using the mixing stirrer (Item 6, Table 1), immediately stir together the fluid elastomer base (Item 4, Table 1) and the solidifier (Item 5, Table 1). Stir for at least two minutes to form the adhesive.

NOTE

Use the entire contents of the mixed adhesive within the times shown in Table 2.

Table 2. Shelf Life Of Mixed Adhesive.

| Temperature | 41°F (5°C) | 59°F (15°C) | 77°F (25°C) |
|-------------------------|--------------|--------------|--------------|
| Use All Material Within | 25.0 minutes | 20.0 minutes | 10.0 minutes |

15. Using one of the brushes (Item 8, Table 1) or the plastic spatula (Item 11, Table 1), apply one even coat of adhesive to the roughened surface of the tank and the prepared patch. The adhesive coat thickness should be approximately 10.0 millimeters (0.025 cm) thick.
16. Let adhesive set until tacky (approximately 5 to 10 minutes). Test by lightly touching one knuckle into adhesive. Lift slowly. When knuckle lifts fabric briefly, and no adhesive is left on knuckle, it is tacky.

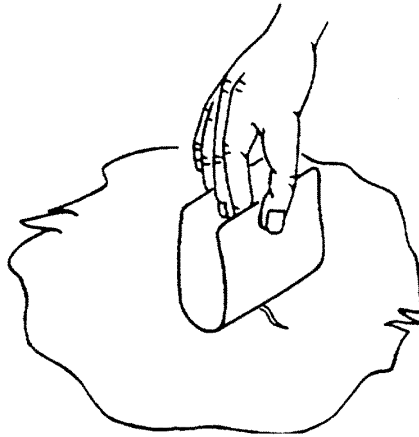

17. Once adhesive is tacky, bring ends of patch together (adhesive side out), and position center of patch onto center of hole as shown.
18. Smooth the patch with the edge of your hand, one end at a time. Avoid any air bubbles.
19. Use a roller, or equivalent, to firmly roll down the entire patch, from center of patch out toward the edges to prevent formation of air bubbles.
20. If a second patch is being applied, proceed with step 21, below; otherwise proceed to step 23.

NOTE

Maximum shelf life of mixed adhesive is listed in Table 2. If a second patch is to be applied, ensure that it is done within the time limit. Repair will not succeed if the mixed adhesive sits too long.

21. Let first patch set for a few (approximately 2 to 3) minutes.
22. Repeat steps 15 through 19, above, to apply second (outside) patch. Outside patch must be aligned with inside patch (outline of inside patch will be visible).
23. Allow repair to set until cured before flexing fabric or putting tank back into service. Approximate curing times are listed in Table 3.

NOTE

Times are for a thickness of approximately 0.10 inches (0.25 cm). Times will be reduced for thicker sections and extended for thinner sections.

Table 3. Curing Time for Fabric Repairs.

| Temperature | Use Involving Movement No Loading or Immersion | Full or Mechanical or Thermal Loading | Immersion in Chemicals |
|-------------|--|---------------------------------------|------------------------|
| 41°F (5°C) | 6 hours | 72 hours | 120 hours |
| 50°F (10°C) | 4 hours | 48 hours | 84 hours |
| 59°F (15°C) | 3 hours | 48 hours | 72 hours |
| 68°F (20°C) | 2 hours | 24 hours | 60 hours |
| 77°F (25°C) | 1.5 hours | 24 hours | 48 hours |
| 86°F (30°C) | 1 hour | 24 hours | 36 hours |

END OF WORK PACKAGE

**OPERATOR, UNIT AND DIRECT SUPPORT MAINTENANCE MANUAL
(INCLUDING REPAIR PARTS SPECIAL TOOLS LIST)
CLAMP ASSEMBLY
INSPECTION, REPAIR AND REPLACEMENT**

INITIAL SETUP**Tools**

Tool Kit, General Mechanics
(Item 1, WP 0027 00)
Torque Wrench, 0-100 ft-lbs
(Item 2, WP 0027 00)

INSPECTION

1. Inspect each of the top center clamps (1) and top left and right hand end clamps (2 and 3) for burrs, sharp edges, and cracks.
2. Inspect each of the bottom center clamps (4) and bottom left and right hand end clamps (5 and 6) for burrs, sharp edges, cracks and damaged threads.
3. Check all cap screws (7) for a proper torque of 70.0 ± 5.0 ft-lbs (95 ± 7 N·m).

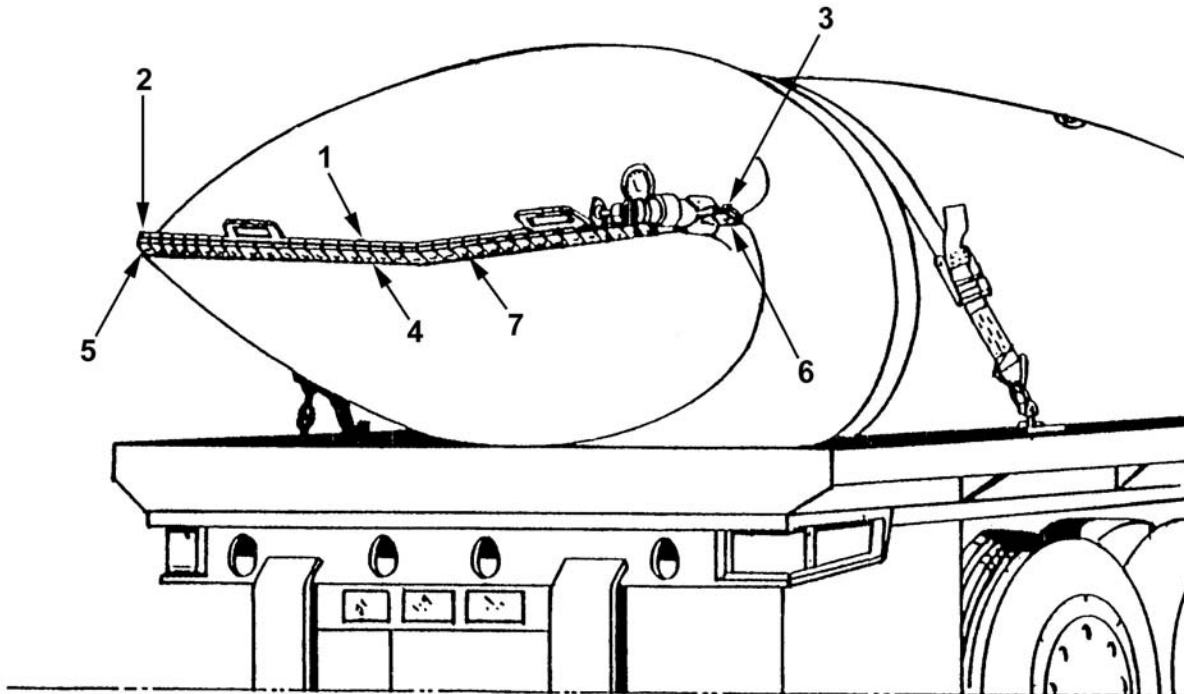

**Tank Model PD62783-3000 shown
(Tank Models PD62783-4750, 91093 and 91094 similar or identical).**

REPAIR

Repair any damage to the clamp assemblies by removing and repairing only one assembly at a time. The right and left, top and bottom end clamps and handles must remain in the original location.

REPLACEMENT**NOTE**

Use the following steps to replace the top and bottom center clamps or the top and bottom end clamps. Top and bottom center clamps are shown.

1. Remove the cap screw (1) and flat washer (2) from top center clamp (3) and bottom center clamp (4).
2. Remove all burrs and sharp edges from the new clamps.
3. If either clamp is cracked or the bottom clamp threads are damaged, replace the clamp.
4. Install top center clamp (3) and bottom center clamp (4) on the tank.
5. Install cap screw (1) through the flat washer (2) and top center clamp (3), and thread it into the bottom center clamp (4).
6. Torque the cap screws (1) to 70.0 ± 5.0 ft-lbs (95 ± 7 N·m).

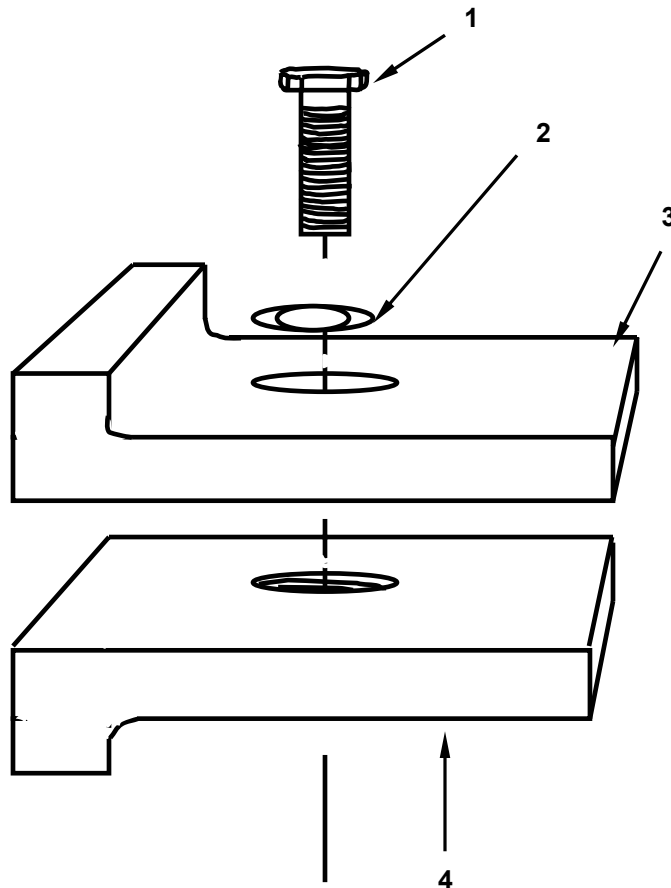

END OF WORK PACKAGE

**OPERATOR, UNIT AND DIRECT SUPPORT MAINTENANCE MANUAL
(INCLUDING REPAIR PARTS AND SPECIAL TOOLS LIST)
FILLER/DISCHARGE ASSEMBLY
INSPECTION, REPAIR AND REPLACEMENT**

INITIAL SETUP**Tools**

Tool Kit, General Mechanics
(Item 1, WP 0027 00)
Torque Wrench, 0-100 ft-lbs
(Item 2, WP 0027 00)

Materials/Parts

Brush, Scrub
(Item 5, WP 0034 00)
Detergent, General Purpose
(Item 3, WP 0034 00)
Rag, Wiping
(Item 4, WP 0034 00)

REMOVAL**Coupling Half**

Unscrew and remove coupling half (1) from gate valve (2).

Pressure Gage

1. Remove pressure gage (3), elbow (4), drain cock (5) and pipe nipple (6) as an assembly from the gate valve (2) flow tube.
2. Remove elbow (4), drain cock (5) and pipe nipple (6) from pressure gage (3).

Gate Valve**NOTE**

It may be necessary to remove two more adjacent top and bottom pipe clamps to remove gate valve.

1. Remove four cap screws and washers from top and bottom pipe clamps (7 and 8) and remove gate valve (2) from tank.
2. Remove inside flange (9) from the gate valve (2) tube.
3. Remove two rubber adaptors (10).

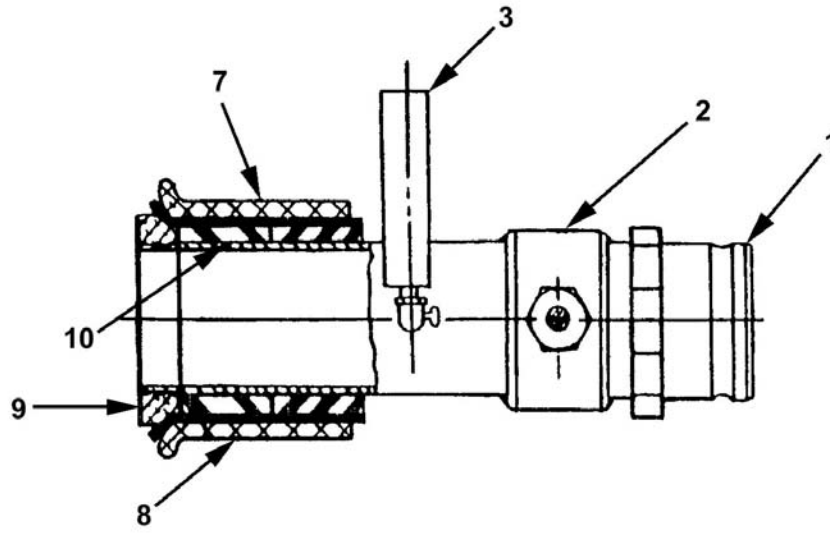

Filler/Discharge Assembly

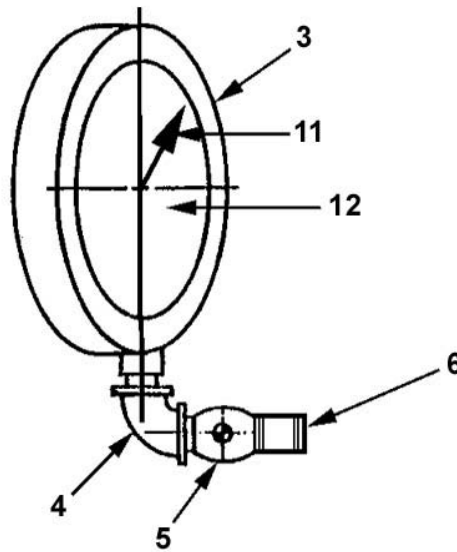

Filler/Discharge Pressure Gage

INSPECTION

1. Clean all parts, sealing surfaces and threaded areas with a mild soap and water solution. Remove any foreign matter with a stiff bristle brush. Wipe parts dry with rags.
2. Inspect coupling half (1) and gate valve (2) for cracks, dents, stripped threads and wear.
3. Inspect pressure gage (3) for a bent indicator (11) or broken faceplate (12). Check pressure gage operation by physically blowing air through the end of pressure gage (3). Average lung pressure should read between 2.0 to 2.5 psi (14 to 17 kPa).
4. Inspect rubber adaptors (10) for cracks, tears and rotting.

REPAIR

1. Replace coupling half (1), gate valve (2) or rubber adaptors (10) if damaged.
2. Replace pressure gage (3) if damaged or if lung pressure test reading is under 2.0 psi (14 kPa).

INSTALLATION**Gate Valve****NOTE**

Moisten the inside of the rubber adaptors for ease of inside flange installation.

1. Install the two rubber adaptors (10) on the gate valve (2) tube.
2. Install the inside flange (9) between the rubber adaptors (10).
3. Align gate valve (2) and top and bottom pipe clamps (7 and 8) on tank. Install four cap screws and washers.
4. If two adjacent top and bottom clamps (7 and 8) were removed, align clamps (7 and 8) and install two more cap screws and washers.
5. Torque all screws to 70.0 ± 5.0 ft-lbs (95 ± 7 N•m).

Pressure Gage

1. Install elbow (4), drain cock (5) and pipe nipple (6) on pressure gage (3).
2. Install pressure gage (3) on the gate valve (2) fill tube.

Coupling Half

Screw coupling half (1) on end of gate valve (2).

END OF WORK PACKAGE

**OPERATOR, UNIT AND DIRECT SUPPORT MAINTENANCE MANUAL
(INCLUDING REPAIR PARTS SPECIAL TOOLS LIST)
HAND GRIP ASSEMBLY
INSPECTION AND REPLACEMENT**

INITIAL SETUP**Tools**

Tool Kit, General Mechanic
(Item 1, WP 0027 00)
Torque Wrench, 0-100 ft-lbs
(Item 2, WP 0027 00)

REMOVAL

1. Remove three cap screws (1) and flat washers (2) from hand grip (3) and three bottom clamps (4).
2. Remove the hand grip (3) and bottom clamps (4) from the tank (5).

INSPECTION

1. Inspect hand grip (3) for cracks or damage.
2. If hand grip (3) is cracked or damaged, replace.

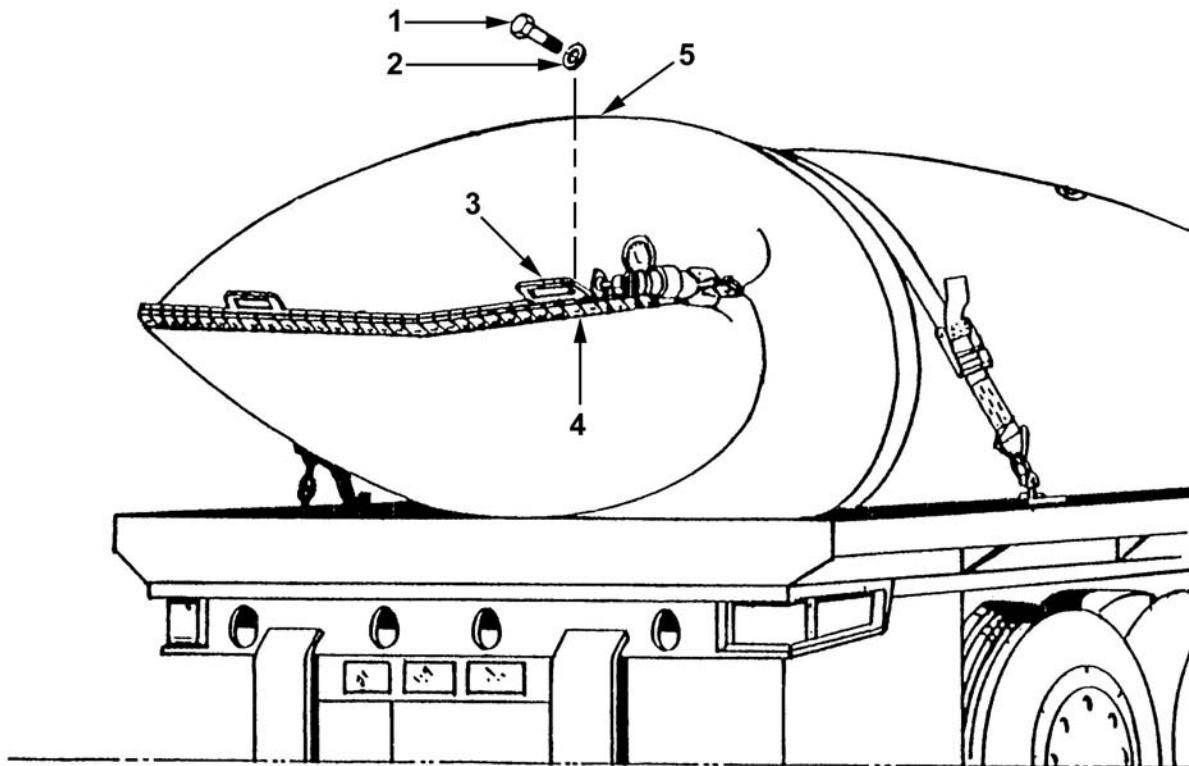

Model 3,000 Gallon tank shown (Models 91093, 5,000 Gallon and 91094 similar or identical)

INSTALLATION

1. Install the new hand grip (3) on top of tank (5) and align the three holes in the tank (5).
2. Assemble one bottom clamp (4) at a time by inserting cap screw (1) through flat washer (2) and the hole in hand grip (3), then thread it into bottom clamp (4). Hand-tighten only.
3. Repeat step 2 to install the other two bottom clamps (4).
4. Torque the three cap screws (1) to 70.0 ± 5.0 ft-lbs (95 ± 7 N•m).

END OF WORK PACKAGE

**OPERATOR, UNIT AND DIRECT SUPPORT MAINTENANCE MANUAL
(INCLUDING REPAIR PARTS AND SPECIAL TOOLS LIST)
TIE-DOWN ASSEMBLY
INSPECTION AND REPLACEMENT**

INITIAL SETUP**Tools**

Tool Kit, General Mechanic
(Item 1, WP 0027 00)

Materials/Parts

Brush, Scrub
(Item 5, WP 0034 00)
Detergent, General Purpose
(Item 3, WP 0034 00)
Rag, Wiping
(Item 4, WP 0034 00)

REMOVAL**Tie-Down Strap Assembly**

1. Remove shackle (1) on each end of strap (2) from eyebolt (3). Remove strap (2) from tank.
2. Remove shackles (1) from strap D-rings (4).

Eyebolt and Retainer Plates

Remove nut (5), lock washer (6) and washer (7) from eyebolt (3). Remove eyebolt (3) and top and bottom retainer plates (8 and 9) from semi-trailer bed or stake pocket.

INSPECTION

1. Clean ratchet take-up mechanism (10) on strap (2), eyebolts (3), retainer plates (8 and 9) and attaching hardware with mild soap and water solution. Remove any foreign matter with a stiff bristle brush. Wipe all parts dry with rags.
2. Inspect strap (2) for abrasions, tears and wear. Inspect ratchet take-up mechanism (10) for cracks, dents, breaks, jammed mechanisms, missing springs and wear. Replace strap (2) if any parts are damaged or missing
3. Inspect eyebolt (3), retainer plates (8 and 9) and attaching hardware for breaks, bends and distortion. Replace damaged parts.

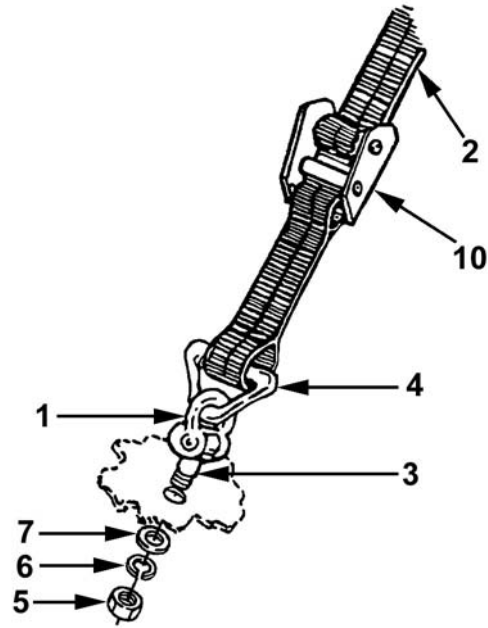

Tie-Down Assembly

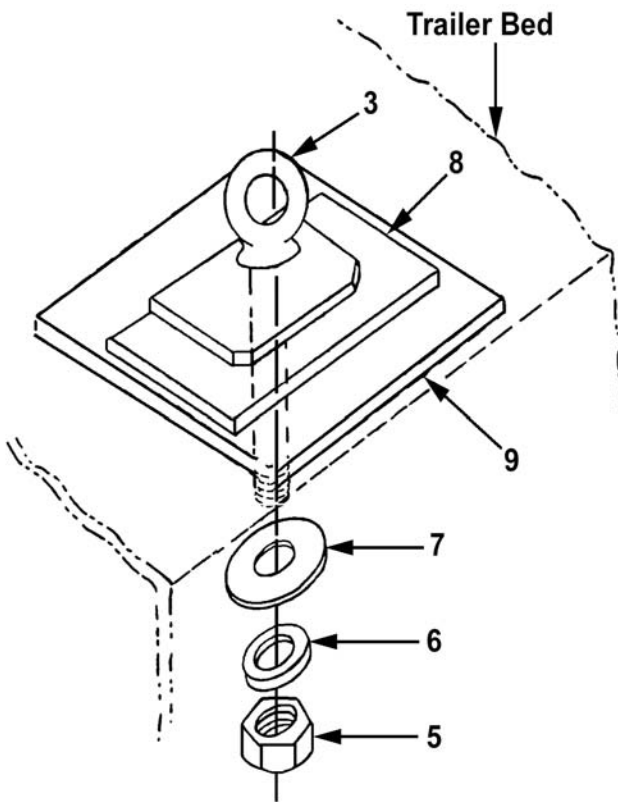

M871 and M872

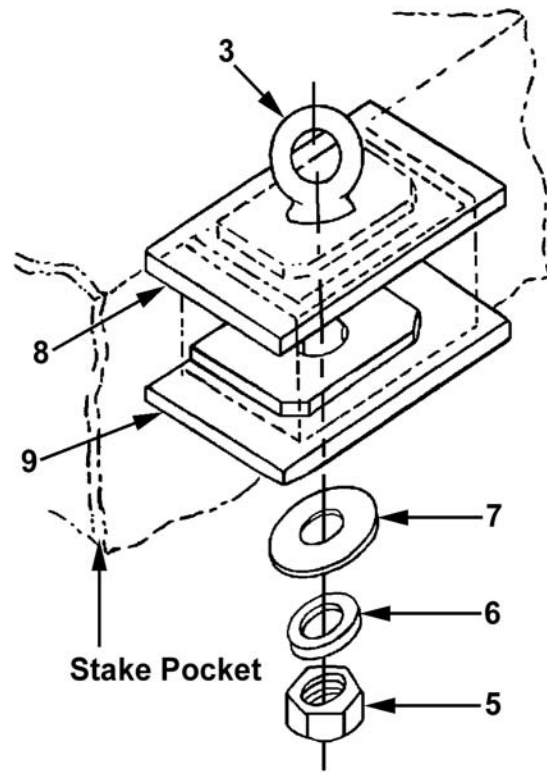

M127

INSTALLATION**Eyebolt and Retainer Plates**

Align top and bottom retainer plates (8 and 9) on semi-trailer bed or stake pocket. Insert eyebolt (3) through retainer plates (8 and 9) and install washer (7), lock washer (6) and nut (5).

Tie-Down Strap Assembly

1. Install shackle (1) to D-ring (4) on each end of strap (2).
2. Position strap (2) on tank and attach shackles (1) to eyebolts (3) on semi-trailer.

END OF WORK PACKAGE

**OPERATOR, UNIT AND DIRECT SUPPORT MAINTENANCE MANUAL
(INCLUDING REPAIR PARTS AND SPECIAL TOOLS LIST)
TANK, FABRIC, COLLAPSIBLE, WATER, 3,000 AND 5,000 GALLONS, SEMI-TRAILER MOUNTED
PREPARATION FOR STORAGE OR SHIPMENT**

PRESERVATION PROCEDURES FOR STORAGE OR SHIPMENT

Emptying the Tank

1. Open the drain valve until the water stops flowing.
2. Lift the four corners of the tank in turn to force the water towards the drain.
3. Pump the tank as dry as possible.
4. Close the drain valve.

Disassembly of the Fittings

1. Disconnect the hoses from the tank.
2. Remove both elbows from the tank and pack in soft packing material (retained in crate when unpacking). Secure the packing with adhesive tape (Item 6, WP 0034 00).
3. Remove the relief cap, 2-inch pipe and coupling half from the vent assembly. Pack in soft packing and secure the packing with adhesive tape (Item 6, WP 0034 00).
4. Place the dust caps on the filler coupling and vent coupling. Pack with soft packing and secure the packing with adhesive tape (Item 6, WP 0034 00).

Draining the tank

CAUTIONS

Make sure tank is completely dry before storing. Water will create mildew, decreasing the life of the tank if it is not completely dry.

The fabric of the tank may be cut or abrade. Only walk on the tank wearing soft soled shoes, which have been wiped clean of all abrasive materials.

1. Slowly, roll the tank up from the filler assembly end. Use the nylon webbing to assist. Water will drain from the discharge coupling and the drain valve.
2. Unroll the tank 15 feet.
3. Clean and dry the tank.
4. Place the dust cap on the discharge coupling and pack with packing material. Secure the packing material with duct tape (Item 7, WP 0034 00).
5. Remove the drain valve and drain hose.
6. Install the plug into the drain assembly.
7. Pack threaded ends of the hose in packing material and secure the packing.
8. Pack the drain valve in packing material and secure the packing.
9. Unroll the tank completely.

PACKING OF TANK AND CRATING INSTRUCTIONS

CAUTION

Use care when packing the tank. The tank can be easily damaged by tools, packing box nails, or other sharp objects.

NOTES

Tank will be packed in a close-fitting box or container. When tank is disassembled and refolded, it is to be replaced in the original box or container.

Each tank is provided with suitable packing around the tank to prevent the tank fabric from being damaged by contact with the inside of the box or container. When tank is replaced in original box or container, the packing material is replaced around the tank in the same manner as received.

1. Remove the pressure gage (2) from the tank (1).
2. Disconnect the hold down ratchets (3) and remove. Hang the loose ends of the belt over the sides of the trailer.
3. Fold the tank (1) almost in half lengthwise. Lay the top fold of the tank (1) down approximately 1 foot shorter than the bottom fold. The ends will be equal when the tank (1) is rolled.
4. Roll the tank (1) manually. It is necessary that the first roll of the tank (1) be circular and tight, otherwise the tank will be difficult to roll and result in a larger tank package.

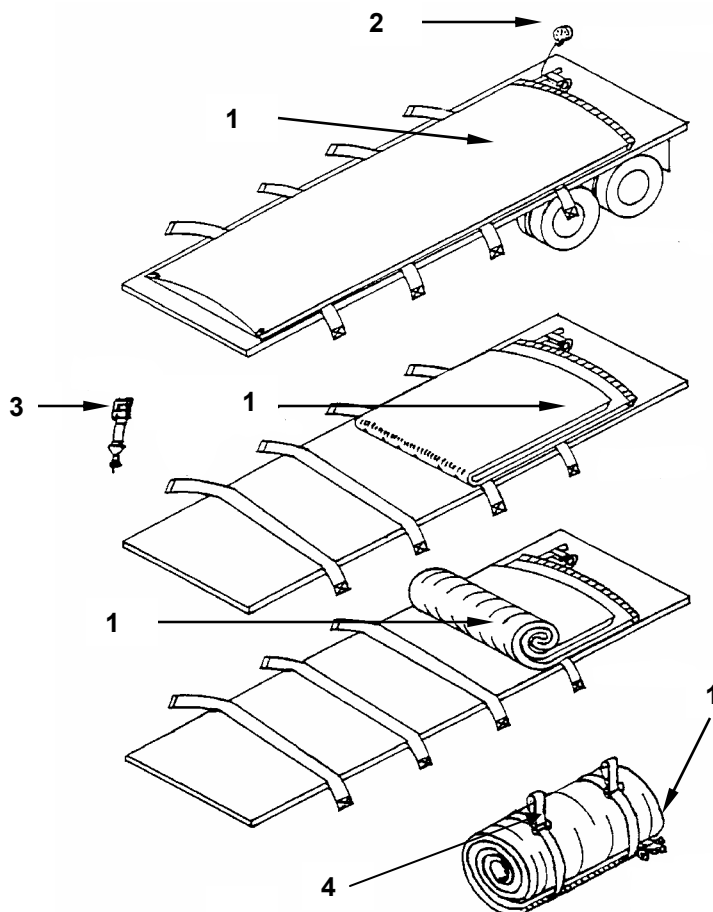

5. The sling (4) may be slipped under the tank (1) if the tank is to be transported to a new location or placed back in its shipping crate (5).

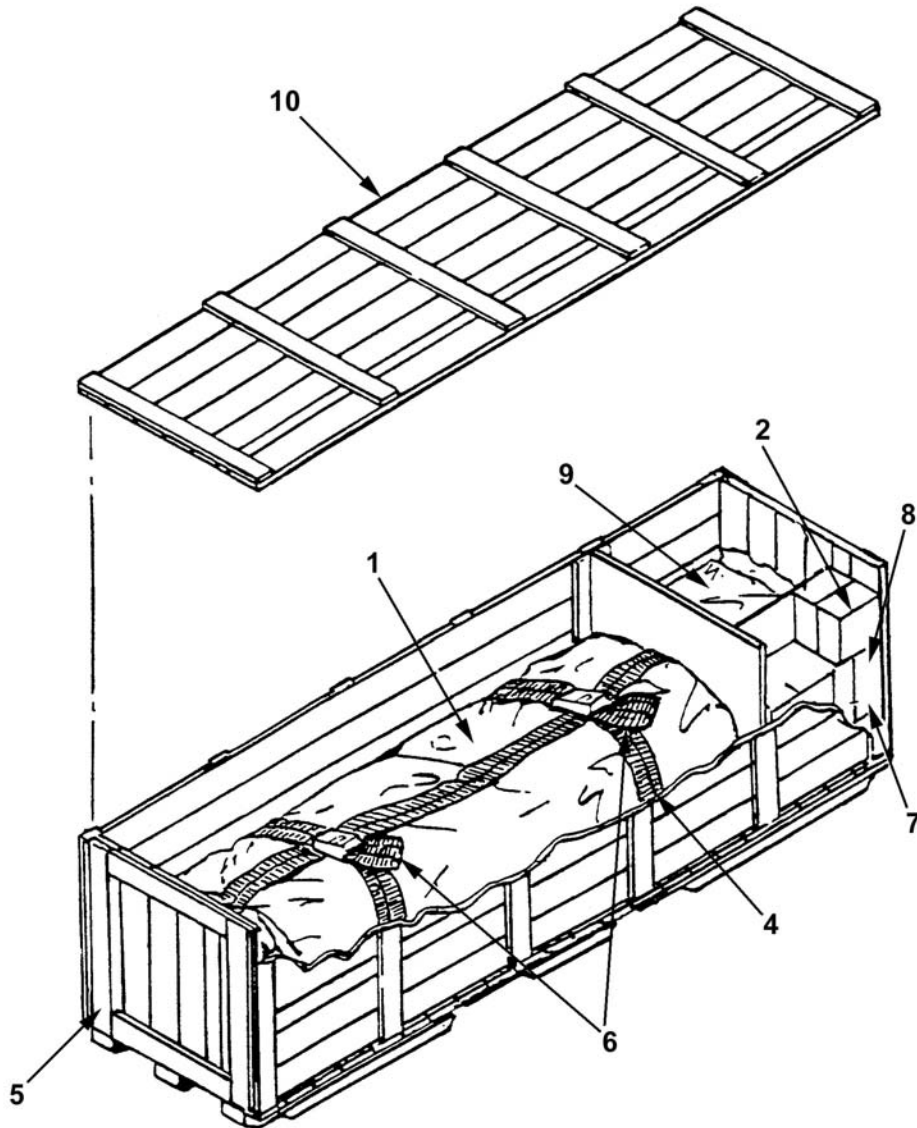

6. Add the boxed emergency repair kit (7) and repair items. The sling (4) is located in the semi-trailer stowage compartment. Fold the semi-trailer bed cloth used for Models 91093 and 91094 only.
7. Roll and store the belts, pressure gage, ratchets, bolts, and plates in a prepared area, preferably in a box container. Pad the pressure gage (2) to avoid damage.
8. Using a suitable lifting device, grab hold of the lift straps (6) of the sling (4) and place the tank (1) into the storage crate (5).
9. The repair items are in a box at the end of the crate (5). These should be placed in a secure place until needed. The tie-down assembly (8) and pressure gage (2) are packaged in the duffle bag (9).
10. Install the crate lid (10) on the crate (5), and secure the crate lid (10) with the crate fastening hardware.

ADMINISTRATIVE STORAGE

1. Placement of equipment in administrative storage should be for short periods of time when a shortage of maintenance effort exists. Items should be in mission readiness within 24 hours or within the time factors as determined by the directing authority. During the storage period, appropriate maintenance records will be kept.
2. Before placing the equipment in administrative storage, current preventive maintenance checks and services should be completed, shortcomings and deficiencies should be corrected, and all Modification Work Orders (MWO) should be applied.
3. Inside storage is preferred for items selected for administrative storage. If inside storage is not available, trucks, vans, conex containers, and other containers may be used.

END OF WORK PACKAGE

CHAPTER 6

DIRECT SUPPORT MAINTENANCE INSTRUCTIONS
FOR
TANK, FABRIC, COLLAPSIBLE, WATER, 3,000 AND 5,000 GALLONS,
SEMI-TRAILER MOUNTED

**OPERATOR, UNIT AND DIRECT SUPPORT MAINTENANCE MANUAL
(INCLUDING REPAIR PARTS SPECIAL TOOLS LIST)
TANK, FABRIC, COLLAPSIBLE, WATER, 3,000 AND 5,000 GALLONS, SEMI-TRAILER MOUNTED
DIRECT SUPPORT REPAIR; TOOLS; SPECIAL TOOLS; TEST, MEASUREMENT
AND DIAGNOSTIC EQUIPMENT (TMDE); AND SUPPORT EQUIPMENT**

COMMON TOOLS AND EQUIPMENT

For authorized common tools and equipment refer to the Modified Table of Organization and Equipment (MTOE) applicable to your unit.

SPECIAL TOOLS, TMDE AND SUPPORT EQUIPMENT

Refer to WP 0029 00 in this manual.

REPAIR PARTS

Repair parts are listed and illustrated in WP 0029 00 of this manual.

END OF WORK PACKAGE

**OPERATOR, UNIT AND DIRECT SUPPORT MAINTENANCE MANUAL
(INCLUDING REPAIR PARTS AND SPECIAL TOOLS LIST)
TANK, FABRIC, COLLAPSIBLE, WATER, 3,000 AND 5,000 GALLONS, SEMI-TRAILER MOUNTED
DIRECT SUPPORT MAINTENANCE PROCEDURES**

GENERAL INSTRUCTIONS

Maintenance instructions in this section will list resources required, personnel required and equipment conditions for start of procedure, except as noted below:

- Personnel required are listed only if the task requires more than one person.
- The normal standard equipment condition to start a maintenance task is with water tank drained and deflated.

EQUIPMENT

Hydrostatic Test

MAINTENANCE PROCEDURE

WP 0025 00

END OF WORK PACKAGE

**OPERATOR, UNIT AND DIRECT SUPPORT MAINTENANCE MANUAL
(INCLUDING REPAIR PARTS AND SPECIAL TOOLS LIST)
HYDROSTATIC TEST**

INITIAL SETUP**Tools**

Tool Kit, General Mechanic
(Item 1, WP 0027 00)
Torque Wrench, 0-100 ft-lbs
(Item 2, WP 0027 00)

Equipment Conditions

Available water supply at 100.0 GPM

Material/parts

Water hose 2.0" ID x 50' long
(Table 1, WP 0033 00)
Gage hose .25" ID x 50' long
(Table 1, WP 0033 00)

WARNING

Do not air test the tank. Over pressurization could cause the tank to burst, resulting in death or serious injury to personnel.

GENERAL

Hydrostatic testing should be performed annually. For tank containers measuring 7.0 foot x 4.0-inch flat, the test pressure is as follows:

1. Initial pressure equals 4.0 PSI (28 kPa). Torque values for bolts are 70.0 ± 5 ft-lbs (95 ± 7 N•m).
2. Static time equals 7.0 PSI (48 kPa) for two hours.
3. Maximum pressure equals 12.0 PSI (83 kPa).
4. Rise time to maximum pressure equals 10 minutes from 7.0 PSI to 12.0 PSI (48 - 83 kPa).

TANK DEPLOYMENT

1. Set the tank on a smooth area for testing and draining.
2. Place the tank in the test area, making certain that all air has been expelled from the tank by flattening the tank completely with the pressure/air relief valve open.
3. Close the pressure/air relief valve before beginning the test.

SETTING UP EQUIPMENT

1. Bleed the air from the filling line to prevent air from entering the tank.
2. Attach the supply hose securely.
3. Attach the .25-inch ID hose to the petcock on the flow tube.
4. Close the petcock and turn on the water.

5. After the tank is partially full (approximately 2.0 foot high), open the petcock on the flow tube and bleed the air from the .25-inch ID hose.
6. Attach both 30.0 PSI (207 kPa) capacity gages.

TESTING

1. Open the petcock and fill the tank with water.
2. When the water pressure in the tank reaches 4.0 PSI (28 kPa), shut off the water supply.
3. Retorque all screws to the recommended torque values.
4. Observe the gages carefully. At 7.0 PSI (48 kPa), immediately shut off the water supply.
5. Allow the tank to stand for two hours. This allows the tank to stretch and adjust to the higher water pressure.
6. After the two hour period, open the supply valve, throttling down the supply valve to approximate a ten minute rise from 7.0 PSI to 12.0 PSI (48 - 83 kPa).

WARNING

When the testing pressure rises above 7.0 PSI (48 kPa), all personnel should be kept at a minimum of 50 feet away from the tank. A tank rupture at high pressure can cause injury.

7. When the pressure reads 12.0 PSI (83 kPa), close the supply valve immediately and open the drain valve on the tank.

CAUTION

Do not let the tank stand at 12.0 PSI (83 kPa) for any length of time as this may overstress the internal cord structure causing damage to the tank.

8. Drain the tank completely.
9. Remove the hoses and, if necessary, dry out the tank.
10. After the hydrostatic test is completed, retorque all bolts to the specified torque specifications.
11. Return the tank to service.

END OF WORK PACKAGE

CHAPTER 7

SUPPORTING INFORMATION
FOR
TANK, FABRIC, COLLAPSIBLE, WATER, 3,000 AND 5,000 GALLONS,
SEMI-TRAILER MOUNTED

**OPERATOR, UNIT, AND DIRECT SUPPORT MAINTENANCE MANUAL
(INCLUDING REPAIR PARTS AND SPECIAL TOOLS LIST)
TANK, FABRIC, COLLAPSIBLE, WATER, 3,000 AND 5,000 GALLONS, SEMI-TRAILER MOUNTED
REFERENCES**

REFERENCES

This work package lists all forms, field manuals, technical manuals and miscellaneous publications referenced in this manual.

TECHNICAL MANUALS

| | |
|----------------|---|
| AR 700-138 | Army Logistics Readiness and Sustainability |
| DA PAM 738-750 | Functional Users Manual for the Army Maintenance Management System (TAMMS) |
| DA PAM 738-751 | Functional Users Manual for the Army Maintenance Management System Aviation (TAMMS-A) |
| TM 750-244-3 | Procedures for Destruction of Equipment to Prevent Enemy Use |

FORMS

| | |
|--------------|---|
| DA Form 2028 | Recommended Changes to Publications and Blank Forms |
| DA Form 2404 | Equipment Inspection and Maintenance Worksheet |
| SF 364 | Report of Discrepancy |
| SF 368 | Product Quality Deficiency Report |

FIELD MANUALS

| | |
|------------------------|-------------------------------------|
| FM 3-3, FM 3-4, FM 3-5 | Detailed Decontamination Procedures |
| FM 21-11 | First Aid |

TECHNICAL BULLETIN

| | |
|-----------|--|
| TB 750-25 | Maintenance of Supplies and Equipment, Army Test Measures and Diagnostic Equipment (TMDE Calibration and Repair Support Program) |
|-----------|--|

MISCELLANEOUS

| | |
|-------------|---|
| CTA 8-100 | Army Medical Dept. Expendable/Durable Items |
| CTA 50-790 | Expendable/Durable Items (except medical, Class V repair parts, and heraldic items) |
| SB 740-99-1 | Storage Serviceability Standard |

END OF WORK PACKAGE

**OPERATOR, UNIT, AND DIRECT SUPPORT MAINTENANCE MANUAL
(INCLUDING REPAIR PARTS AND SPECIAL TOOLS LIST)
TANK, FABRIC, COLLAPSIBLE, WATER, 3,000 AND 5,000 GALLONS, SEMI-TRAILER MOUNTED
MAINTENANCE ALLOCATION CHART**

MAINTENANCE ALLOCATION CHART (MAC)

INTRODUCTION

The Army Maintenance System MAC

This introduction provides a general explanation of all maintenance and repair functions authorized at various maintenance levels under the standard Army Maintenance System concept.

The MAC (immediately following the introduction) designates overall authority and responsibility for the performance of maintenance functions on the identified end item or component. The application of the maintenance functions to the end item or component shall be consistent with the capacities and capabilities of the designated maintenance levels, which are shown on the MAC in column (4) as:

Unit – includes two subcolumns, C (operator/crew) and O (unit) maintenance.

Direct Support – includes an F subcolumn.

General Support – includes an H subcolumn.

Depot – includes a D subcolumn.

The tools and test equipment requirements (immediately following the MAC) list the tools and test equipment (both special tools and common tool sets) required for each maintenance function as referenced from the MAC.

The remarks (immediately following the tools and test equipment requirements) contain supplemental instructions and explanatory notes for a particular maintenance function.

Maintenance Functions

Maintenance functions will be limited to and defined as follows:

1. Inspect - To determine the serviceability of an item by comparing its physical, mechanical, and/or electrical characteristics with established standards through examination (e.g., by sight, sound, or feel). This includes scheduled inspection and gaging and evaluation of cannon tubes.
2. Test - To verify serviceability by measuring the mechanical, pneumatic, hydraulic, or electrical characteristics of an item and comparing those characteristics with prescribed standards on a scheduled basis, i.e., load testing of lift devices and hydrostatic testing of pressure hoses.
3. Service - Operations required periodically to keep an item in proper operating condition; e.g., to clean (includes decontaminate, when required), to preserve, to drain, to paint, or to replenish fuel, lubricants, chemical fluids, or gases. This includes scheduled exercising and purging of recoil mechanisms.
4. Adjust - To maintain or regulate, within prescribed limits, by bringing into proper position, or by setting the operating characteristics to specified parameters.
5. Align - To adjust specified variable elements of an item to bring about optimum or desired performance.
6. Calibrate - To determine and cause corrections to be made or to be adjusted on instruments of test, measuring, and diagnostic equipment used in precision measurement. Consists of comparisons of two instruments, one of which is a certified standard of known accuracy, to detect and adjust any discrepancy in the accuracy of the instrument being compared.

7. Remove/Install - To remove and install the same item when required to perform service or other maintenance functions. Install may be the act of emplacing, seating, or fixing into position a spare, repair part, or module (component or assembly) in a manner to allow the proper functioning of equipment or a system.
8. Replace - To remove an unserviceable item and install a serviceable counterpart in its place. "Replace" is authorized by the MAC and assigned maintenance level is shown as the third position code of the Source, Maintenance and Recoverability (SMR) code.
9. Repair - The application of maintenance services, including fault location/troubleshooting, removal/installation, disassembly/assembly procedures, and maintenance actions to identify troubles and restore serviceability to an item by correcting specific damage, fault, malfunction, or failure in a part, subassembly, module (component or assembly), end item, or system.

NOTE

The following definitions are applicable to the "repair" maintenance function:

Services — Inspect, test, service, adjust, align, calibrate, and/or replace.

Fault location/troubleshooting — The process of investigating and detecting the cause of equipment malfunctioning; the act of isolating a fault within a system or Unit Under Test (UUT).

Disassembly/assembly — The step-by-step breakdown (taking apart) of a spare/functional group coded item to the level of its least component, that is assigned an SMR code for the level of maintenance under consideration (i.e., identified as maintenance significant).

Actions — Welding, grinding, riveting, straightening, facing, machining, and/or resurfacing.

10. Overhaul - That maintenance effort (service/action) prescribed to restore an item to a completely serviceable/operational condition as required by maintenance standards in appropriate technical publications. Overhaul is normally the highest degree of maintenance performed by the Army. Overhaul does not normally return an item to like new condition.
11. Rebuild - Consists of those services/actions necessary for the restoration of unserviceable equipment to a like new condition in accordance with original manufacturing standards. Rebuild is the highest degree of materiel maintenance applied to Army equipment. The rebuild operation includes the act of returning to zero those age measurements (e.g., hours/miles) considered in classifying Army equipment/components.

Explanation of Columns In The MAC

Column (1) — Group Number. Column (1) lists FGC numbers, the purpose of which is to identify maintenance significant components, assemblies, subassemblies, and modules with the Next Higher Assembly (NHA).

Column (2) — Component/Assembly. Column (2) contains the item names of components, assemblies, subassemblies, and modules for which maintenance is authorized.

Column (3) — Maintenance Function. Column (3) lists the functions to be performed on the item listed in column (2). (For a detailed explanation of these functions refer to "Maintenance Functions" outlined above.)

Column (4) — Maintenance Level. Column (4) specifies each level of maintenance authorized to perform each function listed in column (3), by indicating work time required (expressed as manhours in whole hours or decimals) in the appropriate subcolumn. This work time figure represents the active time required to perform that maintenance function at the indicated level of maintenance. If the number or complexity of the

tasks within the listed maintenance function varies at different maintenance levels, appropriate work time figures are to be shown for each level. The work time figure represents the average time required to restore an item (assembly, subassembly, component, module, end item, or system) to a serviceable condition under typical field operating conditions. This time includes preparation time (including any necessary disassembly/assembly time), troubleshooting/fault location time, and quality assurance time in addition to the time required to perform the specific tasks identified for the maintenance functions authorized in the MAC. The symbol designations for the various maintenance levels are as follows:

C — Operator or crew maintenance

O — Unit maintenance

F — Direct support maintenance

L — Specialized repair activity (SRA)

H — General support maintenance

D — Depot maintenance

NOTE

The “L” maintenance level is not included in column (4) of the MAC. Functions to this level of maintenance are identified by a work time figure in the “H” column of column (4), and an associated reference code is used in the REMARKS column (6). This code is keyed to the remarks and the SRA complete repair application is explained there.

Column (5) — Tools and Equipment Reference Code. Column (5) specifies, by code, those common tool sets (not individual tools), common Test, Measurement and Diagnostic Equipment (TMDE), and special tools, special TMDE and special support equipment required to perform the designated function. Codes are keyed to the entries in the tools and test equipment table.

Column (6) — Remarks Code. When applicable, this column contains a letter code, in alphabetical order, which is keyed to the remarks table entries.

Explanation of Columns in the Tools and Test Equipment Requirements

Column (1) — Tool or Test Equipment Reference Code. The tool or test equipment reference code correlates with a code used in column (5) of the MAC.

Column (2) — Maintenance Level. The lowest level of maintenance authorized to use the tool or test equipment.

Column (3) — Nomenclature. Name or identification of the tool or test equipment.

Column (4) — National Stock Number (NSN). The NSN of the tool or test equipment.

Column (5) — Tool Number. The manufacturer’s part number, model number, or type number.

Explanation of Columns in the Remarks

Column (1) — Remarks Code. The code recorded in column (6) of the MAC.

Column (2) — Remarks. This column lists information pertinent to the maintenance function being performed as indicated in the MAC.

Table 1. MAC for Tank, Water, 3,000 and 5,000 Gallons, Semi-trailer Mounted.

| (1) GROUP NUMBER | (2) COMPONENT/ ASSEMBLY | (3) MAINTENANCE FUNCTION | (4) MAINTENANCE LEVEL | | | | | (5) TOOLS AND EQUIPMENT REFERENCE CODE | (6) REMARKS CODE |
|------------------------|----------------------------------|--------------------------------|--------------------------|-----|-----|----|-------|--|------------------------|
| | | | UNIT | | DS | GS | DEPOT | | |
| | | | C | O | F | H | D | | |
| 00 | Tank Assembly | Inspect | 0.3 | | | | | | |
| | | Replace | | 0.3 | | | | 1, 2 | A, B |
| | | Repair | 0.3 | 4.0 | | | | 1, 2 | A, B, D |
| | | Test | | | 4.0 | | | 1, 2 | C |
| 01 | Hose Assembly | Inspect | 0.2 | | | | | | |
| | | Replace | | 0.2 | | | | | B |
| | | Repair | | 0.5 | | | | 1 | |
| 02 | Filler/ Discharge Assembly | Inspect | 0.2 | | | | | | |
| | | Replace | | 0.2 | | | | 1,2 | B |
| | | Repair | | 0.5 | | | | 1,2 | B |
| 03 | Emergency Repair Items | Inspect | 0.2 | | | | | | A, B |
| | | Install | 1.0 | | | | | | A, B |
| | | Replace | 0.2 | | | | | | A, B |
| 04 | Tie Down Assembly | Inspect | 0.2 | | | | | | A, B |
| | | Repair | | 0.4 | | | | | A, B |
| | | Replace | | 0.2 | | | | 1, 2 | |
| 05 | Accessories | Inspect | 0.1 | | | | | | B |
| | | Replace | 0.2 | | | | | | |

Table 2. Tools and Test Equipment for Tank, Water, 3,000 and 5,000 Gallons, Semi-trailer Mounted.

| TOOL OR TEST EQUIPMENT REFERENCE CODE | MAINTENANCE LEVEL | NOMENCLATURE | NATIONAL STOCK NUMBER (NSN) | TOOL NUMBER |
|---------------------------------------|-------------------|---|-----------------------------|-------------------|
| 1 | O | Tool Kit, General Mechanics | 5180-00-177-7033 | SC-5180-90-CL-N26 |
| 2 | O | Shop Equipment, Automotive Maintenance and Repair | 4910-00-754-0654 | SC-4910-95-CL-A74 |

Table 3. Remarks for Tank, Water, 3,000 and 5,000 Gallons, Semi-trailer Mounted.

| REMARKS CODE | REMARKS |
|--------------|---|
| A | Crew level repair limited to installation of sealing clamps and wood plugs. |
| B | Repair by replacing defective components. |
| C | Hydrostatic testing should be done annually (WP 0025 00). |
| D | Operator or Unit Maintenance accomplishes temporary repairs, large repairs by Direct Support. |

END OF WORK PACKAGE

**OPERATOR, UNIT, AND DIRECT SUPPORT MAINTENANCE MANUAL
(INCLUDING REPAIR PARTS AND SPECIAL TOOLS LIST)
TANK, FABRIC, COLLAPSIBLE, WATER, 3,00 AND 5,000 GALLONS, SEMI-TRAILER MOUNTED
REPAIR PARTS INTRODUCTION**

INTRODUCTION

SCOPE

This RPSTL lists and authorizes spares and repair parts; special tools; special test, measurement, and diagnostic equipment (TMDE); and other special support equipment required for performance of maintenance on the Tank. It authorizes the requisitioning, issue, and disposition of spares, repair parts and special tools as indicated by the source, maintenance and recoverability (SMR) codes.

GENERAL

In addition to the Introduction work package, this RPSTL is divided into the following work packages:

1. Repair Parts List Work Packages. Work packages containing lists of spares and repair parts authorized by this RPSTL for use in the performance of maintenance. These work packages also include parts, which must be removed for replacement of the authorized parts. Parts lists are composed of functional groups in ascending alphanumeric sequence, with the parts in each group listed in ascending figure and item number sequence. Bulk materials are listed by item name in FIG. BULK at the end of the work packages. Repair parts kits are listed separately in their own functional group and work package. Repair parts for reparable special tools are also listed in a separate work package. Items listed are shown on the associated illustrations.
2. Special Tools List Work Packages. Work packages containing lists of special tools, special TMDE, and special support equipment authorized by this RPSTL (as indicated by Basis of Issue (BOI) information in the DESCRIPTION AND USABLE ON CODE (UOC) column). Tools that are components of common tool sets and/or Class VII are not listed.
3. Cross-Reference Indexes Work Packages. There are two cross-reference indexes work packages in this RPSTL: the National Stock Number (NSN) Index work package and the Part Number (P/N) Index work package. The National Stock Number Index work package refers you to the figure and item number. The Part Number Index work package refers you to the figure and item number.

EXPLANATION OF COLUMNS IN THE REPAIR PARTS LIST AND SPECIAL TOOLS LIST WORK PACKAGES

ITEM NO. (Column (1)). Indicates the number used to identify items called out in the illustration.

SMR Code (Column (2)). The SMR code containing supply/requisitioning information, maintenance level authorization criteria, and disposition instruction, as shown in the following breakout:

| <u>Source Code</u> | <u>Maintenance Code</u> | | <u>Recoverability Code</u> |
|---|--|---|--|
| <u>xx</u> | <u>xx</u> | | <u>x</u> |
| 1 st two positions: How to get an item. | 3 rd position: Who can install, replace or use the item. | 4 th position: Who can do complete repair* on the item. | 5 th position: Who determines disposition action on unserviceable items. |

*Complete Repair: Maintenance capacity, capability, and authority to perform all corrective maintenance tasks of the "Repair" function in a use/user environment in order to restore serviceability to a failed item.

Source Code. The source code tells you how you get an item needed for maintenance, repair, or overhaul of an end item/equipment. Explanations of source codes follow.

Source Code**Application/Explanation**

PA
PB
PC
PD
PE
PF
PG

Stocked items; use the applicable NSN to request/requisition items with these source codes. They are authorized to the level indicated by the code entered in the 3rd position of the SMR code.

NOTE

Items coded PC are subject to deterioration.

KD
KF
KB

Items with these codes are not to be requested/requisitioned individually. They are part of a kit which is authorized to the maintenance level indicated in the 3rd position of the SMR code. The complete kit must be requisitioned and applied.

MO-Made at unit/
AVUM level
MF-Made at DS/
AVIM level
MH-Made at GS
level
ML-Made at SRA
MD-Made at depot

Items with these codes are not to be requested/requisitioned individually. They must be made from bulk material which is identified by the P/N in the DESCRIPTION AND USABLE ON CODE (UOC) column and listed in the bulk material group work package of the RPSTL. If the item is authorized to you by the 3rd position code of the SMR code, but the source code indicates it is made at higher level, order the item from the higher level of maintenance.

AO-Assembled by
unit/AVUM level
AF-Assembled by
DS/AVIM level
AH-Assembled by
GS level
AL-Assembled by
SRA
AD-Assembled by
depot

Items with these codes are not to be requested/requisitioned individually. The parts that make up the assembled item must be requisitioned or fabricated and assembled at the level of maintenance indicated by the source code. If the 3rd position of the SMR code, authorizes you to replace the item, but the source code indicates the item is assembled at a higher level, order the item from the higher level of maintenance.

XA

Do not requisition an "XA" coded item. Order the next higher assembly. (Refer to the NOTE below.)

XB

If an item is not available from salvage, order it using the CAGEC and P/N.

XC

Installation drawings, diagrams, instruction sheets, field service drawings; identified by manufacturer's P/N.

XD

Item is not stocked. Order an XD-coded item through normal supply channels using the CAGEC and P/N given, if no NSN is available.

NOTE

Cannibalization or controlled exchange, when authorized, may be used as a source of supply for items with the above source codes except for those items source coded "XA" or those aircraft support items restricted by requirements of AR 750-1.

Maintenance Code. Maintenance codes tell you the level(s) of maintenance authorized to use and repair support items. The maintenance codes are entered in the third and fourth positions of the SMR code as follows:

Third Position. The maintenance code entered in the third position tells you the lowest maintenance level authorized to remove, replace, and use an item. The maintenance code entered in the third position will indicate authorization to the following levels of maintenance.

| <u>Maintenance Code</u> | <u>Application/Explanation</u> |
|--------------------------------|---------------------------------------|
|--------------------------------|---------------------------------------|

| | | |
|---|----|--|
| C | -- | Crew or operator maintenance done within unit/AVUM maintenance. |
| O | -- | Unit level/AVUM maintenance can remove, replace, and use the item. |
| F | -- | Direct support/AVIM maintenance can remove, replace, and use the item. |
| H | -- | General support maintenance can remove, replace, and use the item. |
| L | -- | Specialized repair activity can remove, replace, and use the item. |
| D | -- | Depot can remove, replace, and use the item. |

Fourth Position. The maintenance code entered in the fourth position tells whether the item is to be repaired and identifies the lowest maintenance level with the capability to do complete repair (perform all authorized repair functions).

NOTE

Some limited repair may be done on the item at a lower level of maintenance, if authorized, by the Maintenance Allocation Chart (MAC) and SMR codes.

| <u>Maintenance Code</u> | <u>Application/Explanation</u> |
|--------------------------------|---------------------------------------|
|--------------------------------|---------------------------------------|

| | | |
|---|----|---|
| O | -- | Unit/AVUM is the lowest level that can do complete repair of the item. |
| F | -- | Direct support/AVIM is the lowest level that can do complete repair of the item. |
| H | -- | General support is the lowest level that can do complete repair of the item. |
| L | -- | Specialized repair activity is the lowest level that can do complete repair of the item. |
| D | -- | Depot is the lowest level that can do complete repair of the item. |
| Z | -- | Non-reparable. No repair is authorized. |
| B | -- | No repair is authorized. No parts or special tools are authorized for maintenance of a "B" coded item. However, the item may be reconditioned by adjusting, lubricating, etc., at the user level. |

Recoverability Code. Recoverability codes are assigned to items to indicate the disposition action on unserviceable items. The recoverability code is entered in the fifth position of the SMR Code as follows:

| <u>Recoverability Code</u> | <u>Application/Explanation</u> |
|----------------------------|---|
| Z -- | Nonreparable item. When unserviceable, condemn and dispose of the item at the level of maintenance shown in the third position of the SMR Code. |
| O -- | Reparable item. When uneconomically repairable, condemn and dispose of the item at the unit level. |
| F -- | Reparable item. When uneconomically repairable, condemn and dispose of the item at the direct support level. |
| H -- | Reparable item. When uneconomically repairable, condemn and dispose of the item at the general support level. |
| D -- | Reparable item. When beyond lower level repair capability, return to depot. Condemnation and disposal of item are not authorized below depot level. |
| L -- | Reparable item. Condemnation and disposal not authorized below Specialized Repair Activity (SRA). |
| A -- | Item requires special handling or condemnation procedures because of specific reasons (such as precious metal content, high dollar value, critical material, or hazardous material). Refer to appropriate manuals/directives for specific instructions. |

NSN (Column (3)). The NSN for the item is listed in this column.

CAGEC (Column (4)). The Commercial and Government Entity Code (CAGEC) is a five-digit code, which is used to identify the manufacturer, distributor, or Government agency/activity that supplies the item.

PART NUMBER (Column (5)), indicates the primary number used by the manufacturer (individual, company, firm, corporation, or Government activity), which controls the design and characteristics of the item by means of its engineering drawings, specifications, standards, and inspection requirements to identify an item or range of items.

NOTE

When you use an NSN to requisition an item, the item you receive may have a different P/N from the number listed.

DESCRIPTION AND USABLE ON CODE (UOC) (Column (6)). This column includes the following information:

1. The federal item name and, when required, a minimum description to identify the item.
2. P/Ns of bulk materials are referenced in this column in the line entry to be manufactured or fabricated.
3. Hardness Critical Item (HCI). A support item that provides the equipment with special protection from electro-magnetic pulse (EMP) damage during a nuclear attack.
4. The statement END OF FIGURE appears just below the last item description in Column (6) for a given figure in both the repair parts list and special tools list work packages.

QTY (Column (7)). The QTY (quantity per figure) column indicates the quantity of the item used in the breakout shown on the illustration/figure, which is prepared for a functional group, subfunctional group, or an assembly. A "V" appearing in this column instead of a quantity indicates that the quantity is variable and quantity may change from application to application.

EXPLANATION OF CROSS-REFERENCE INDEXES WORK PACKAGES FORMAT AND COLUMNS

1. National Stock Number (NSN) Index Work Package.

STOCK NUMBER Column. This column lists the NSN in National item identification number (NIIN) sequence. The NIIN consists of the last nine digits of the NSN.

NSN
 (e.g., 5385-01-574-1476)
NIIN

When using this column to locate an item, ignore the first four digits of the NSN. However, the complete NSN should be used when ordering items by stock number.

FIG. Column. This column lists the number of the figure where the item is identified/located. The figures are in numerical order in the repair parts list and special tools list work packages.

ITEM Column. The item number identifies the item associated with the figure listed in the adjacent FIG. column. This item is also identified by the NSN listed on the same line.

2. Part Number (P/N) Index Work Package. P/Ns in this index are listed in ascending alphanumeric sequence (vertical arrangement of letter and number combinations which places the first letter or digit of each group in order A through Z, followed by the numbers 0 through 9 and each following letter or digit in like order).

PART NUMBER Column. Indicates the P/N assigned to the item.

FIG. Column. This column lists the number of the figure where the item is identified/located in the repair parts list and special tools list work packages.

ITEM Column. The item number is the number assigned to the item as it appears in the figure referenced in the adjacent figure number column.

SPECIAL INFORMATION

UOC. The UOC appears in the lower left corner of the Description Column heading. Usable on codes are shown as "UOC:..." in the Description Column (justified left) on the first line under the applicable item/nomenclature. Uncoded items are applicable to all models. Identification of the UOCs used in the RPSTL are:

| <u>Code</u> | <u>Used On</u> |
|-------------|--------------------|
| FGC | Model PD62783-3000 |
| FGK | Model 91093 |
| EZR | Model PD62783-4750 |
| FGL | Model 91094 |

Fabrication Instructions. Bulk materials required to manufacture items are listed in the bulk material functional group of this RPSTL. Part numbers for bulk material are also referenced in the Description Column of the line item entry for the item to be manufactured/fabricated. Detailed fabrication instructions for items source coded to be manufactured or fabricated are found in this manual.

Index Numbers. Items which have the word BULK in the figure column will have an index number shown in the item number column. This index number is a cross-reference between the NSN/P/N index work packages and the bulk material list in the repair parts list work package.

Illustrations List. The illustrations in this RPSTL contain authorized items.

HOW TO LOCATE REPAIR PARTS

1. When NSNs or P/Ns Are Not Known.

First. Using the table of contents, determine the assembly group to which the item belongs. This is necessary since figures are prepared for assembly groups and subassembly groups, and lists are divided into the same groups.

Second. Find the figure covering the functional group or the sub functional group to which the item belongs.

Third. Identify the item on the figure and note the number(s).

Fourth. Look in the repair parts list work packages for the figure and item numbers. The NSNs and part numbers are on the same line as the associated item numbers.

2. When NSN Is Known.

First. If you have the NSN, look in the STOCK NUMBER column of the NSN index work package. The NSN is arranged in NIIN sequence. Note the figure and item number next to the NSN.

Second. Turn to the figure and locate the item number. Verify that the item is the one you are looking for.

3. When P/N Is Known.

First. If you have the P/N and not the NSN, look in the PART NUMBER column of the P/N index work package. Identify the figure and item number.

Second. Look up the item on the figure in the applicable repair parts list work package.

END OF WORK PACKAGE

OPERATOR, UNIT, AND DIRECT SUPPORT MAINTENANCE

TANK, FABRIC, COLLAPSIBLE, WATER, 3,000 AND 5,000 GALLONS, SEMI-TRAILER MOUNTED

TANK ASSEMBLY

REPAIR PARTS LIST

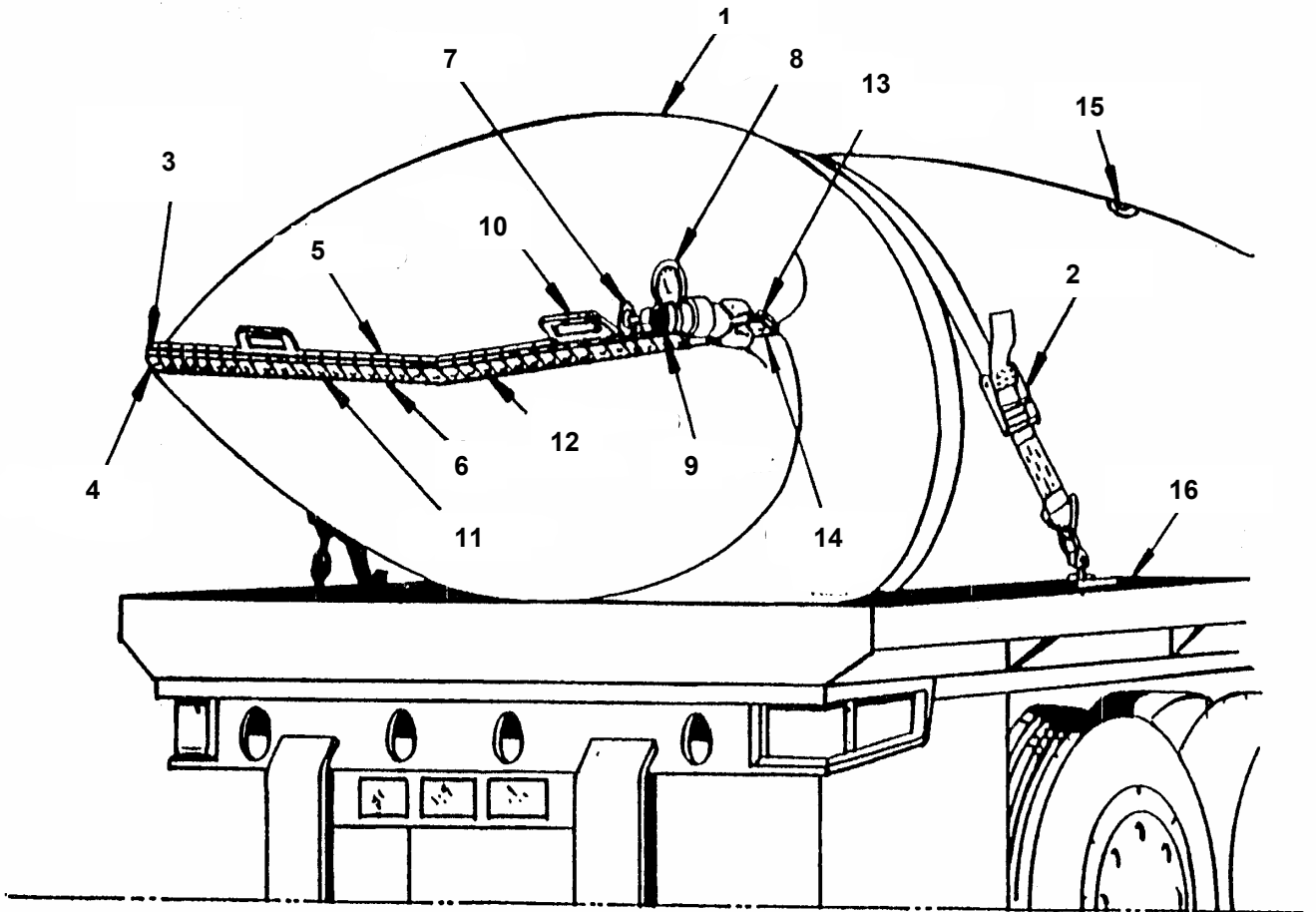

Figure 1. Tank Assemblies and Hardware.

| (1) | (2) | (3) | (4) | (5) | (6) | (7) |
|----------|----------|------------------|-------|--------------|--|-----|
| ITEM NO. | SMR CODE | NSN | CAGEC | PART NUMBER | DESCRIPTION AND USABLE ON CODE (UOC) | QTY |
| | | | | | GROUP 00 | |
| | | | | | FIGURE. 1. TANK ASSEMBLIES AND HARDWARE | |
| | PDOFF | 5430-01-181-4071 | 97403 | PD62783-3000 | TANK ASSEMBLY, COLLAPSIBLE, 3,000 GALLONS UOC: FGC..... | 1 |
| | PDOFF | 5430-01-372-6901 | 05476 | 91093 | TANK ASSEMBLY, COLLAPSIBLE, 3,000 GALLONS UOC: FGK..... | 1 |
| | PDOFF | 5430-01-120-7823 | 97403 | PD62783-4750 | TANK ASSEMBLY, COLLAPSIBLE, 5,000 GALLONS UOC: EZR..... | 1 |
| | PDOFF | 5430-01-372-6900 | 05476 | 91094 | TANK ASSEMBLY, COLLAPSIBLE, 5,000 GALLONS UOC: FGL..... | 1 |
| 1 | XAOOO | | | | .TANK, COLLAPSIBLE, UOC: FGC..... | 1 |
| 1 | XAOOO | | 05476 | RE231 | .TANK, COLLAPSIBLE UOC: FGK..... | 1 |
| 1 | XAOOO | | 81349 | M53055A-II | .TANK, COLLAPSIBLE UOC: EZR..... | 1 |
| 1 | XAOOO | | 05476 | RE230 | .TANK, COLLAPSIBLE UOC: FGL..... | 1 |
| 2 | XDOZZ | | 00333 | 5332.0539 | .TIE DOWN, 2 IN STRAP; BEIGE, 26 FT, WITH 2 LOCKING TAKE-UP RATCHETS UOC: EZR, FGC..... | 5 |
| 2 | XDOZZ | | 05476 | FCD64631-1 | .BELT, TIEDOWN ASSY; 3 INCH X 33 FT LONG, BEIGE UOC: FGK, FGL..... | 4 |
| 2 | XDOZZ | | 05476 | FCD64632-1 | .BELT, TIEDOWN ASSY; 2 INCH X 33 FT LONG, BEIGE UOC: FGK..... | 4 |
| 3 | XDOZZ | | 00333 | 5332.0546 | .CLAMP, TOP, LEFT HAND UOC: EZR, FGC..... | 2 |
| 3 | XBOZZ | | 05476 | HC-439-1 | .CLAMP, CORNER LEFT HAND, TOP UOC: FGK, FGL..... | 2 |

| (1) | (2) | (3) | (4) | (5) | (6) | (7) |
|----------|----------|------------------|-------|-------------------|--|----------|
| ITEM NO. | SMR CODE | NSN | CAGEC | PART NUMBER | DESCRIPTION AND USABLE ON CODE (UOC) | QTY |
| 4 | XDOZZ | | 00333 | 5332.0547 | .CLAMP, BTM, LEFT HAND UOC: EZR, FGC..... | 2 |
| 4 | XBOZZ | | 05476 | HC-440-2 | .CLAMP, CORNER LEFT HAND, BOTTOM UOC: FGK, FGL..... | 2 |
| 5 | XDOZZ | | 00333 | 5332.0198 | .CLAMP, TOP, CENTER UOC: EZR, FGC..... | 27 |
| 5 | XBOZZ | | 05476 | HC-270-3 | .CLAMP, TOP, CENTER UOC: FGK, FGL..... | 27 |
| 6 | XDOZZ | | 00333 | 5332.6495 | .CLAMP, BTM, CENTER UOC: EZR, FGC..... | 39 |
| 6 | XBOZZ | | 05476 | HC-270-2 | .CLAMP, BTM, CENTER UOC: FGK, FGL..... | 33 |
| 7 | XDOZZ | | 00333 | 5332.0552 | .VALVE, GATE, 4 INCH UOC: EZR, FGC..... | 1 |
| 7 | XBOZZ | | 05476 | HD-545-8 | .VALVE, GATE, 4 INCH UOC: FGK, FGL..... | 1 |
| 8 | PAOZZ | 6685-01-360-1874 | 39428 | 4089K33 | .GAGE, PRESSURE, DIAL 0 TO 15 PSI..... | 1 |
| 9 | XDOZZ | 4730-00-840-0797 | 96906 | MS27022-17 | .COUPLING HALF, QUICK DISCONNECT, FEMALE, 4 IN NPT UOC: EZR, FGC..... | 1 |
| 9 | PAOZZ | 4730-00-840-0796 | 58536 | AA59326119 | .COUPLING HALF, QUICK DISCONNECT, FEMALE, 4 IN NPT UOC: FGK, FGL..... | 1 |
| 10 | XDOZZ | | 00333 | 5332.0312 | .HAND GRIP UOC: EZR, FGC..... | 2 |
| 10 | XBOZZ | | 05476 | HC-273-3 | .GRIP, HAND UOC: FGK, FGL..... | 2 |
| 11 | XDOZZ | 5310-01-163-0602 | 80205 | NAS1149D106 3K | .WASHER, FLAT UOC: EZR, FGC..... UOC: FGK, FGL..... | 43 41 |
| 12 | XDOZZ | 5306-00-469-5339 | 96906 | MS16208-141 | .BOLT, MACHINE, 1/2-13 X 2 1/2 UOC: EZR, FGC..... UOC: FGK, FGL..... | 43 41 |
| 13 | XDOZZ | | 00333 | 5332.0548 | .CLAMP, TOP, RGT HAND UOC: EZR, FGC..... | 2 |

| (1) | (2) | (3) | (4) | (5) | (6) | (7) |
|----------|----------|-----|-------|-------------|--|-----|
| ITEM NO. | SMR CODE | NSN | CAGEC | PART NUMBER | DESCRIPTION AND USABLE ON CODE (UOC) | QTY |
| 13 | XBOZZ | | 05476 | HC-440-1 | .CLAMP, CORNER RIGHT HAND, TOP UOC: FGK, FGL..... | 2 |
| 14 | XDOZZ | | 00333 | 5332.0550 | .CLAMP, BOT, RGT HAND UOC: EZR, FGC..... | 2 |
| 14 | XBOZZ | | 05476 | HC-439-2 | .CLAMP, CORNER RIGHT HAND BOTTOM UOC: FGK, FGL..... | 2 |
| 15 | XDOZZ | | 00333 | 5332.1141 | .VALVE, RELIEF UOC: EZR, FGC..... | 1 |
| 15 | XAOZZ | | 17673 | P-800 | .VALVE ASSY, RELIEF UOC: FGK, FGL..... | 1 |
| 16 | XBOZZ | | 05476 | 90082 | .BEDCLOTH UOC: FGK..... | 1 |
| 16 | XBOZZ | | 05476 | 90084 | .BEDCLOTH UOC: FGL..... | 1 |

END OF FIGURE

OPERATOR, UNIT, AND DIRECT SUPPORT MAINTENANCE

TANK, FABRIC, COLLAPSIBLE, WATER, 3,000 AND 5,000 GALLONS, SEMI-TRAILER MOUNTED

HOSE ASSEMBLY

REPAIR PARTS LIST

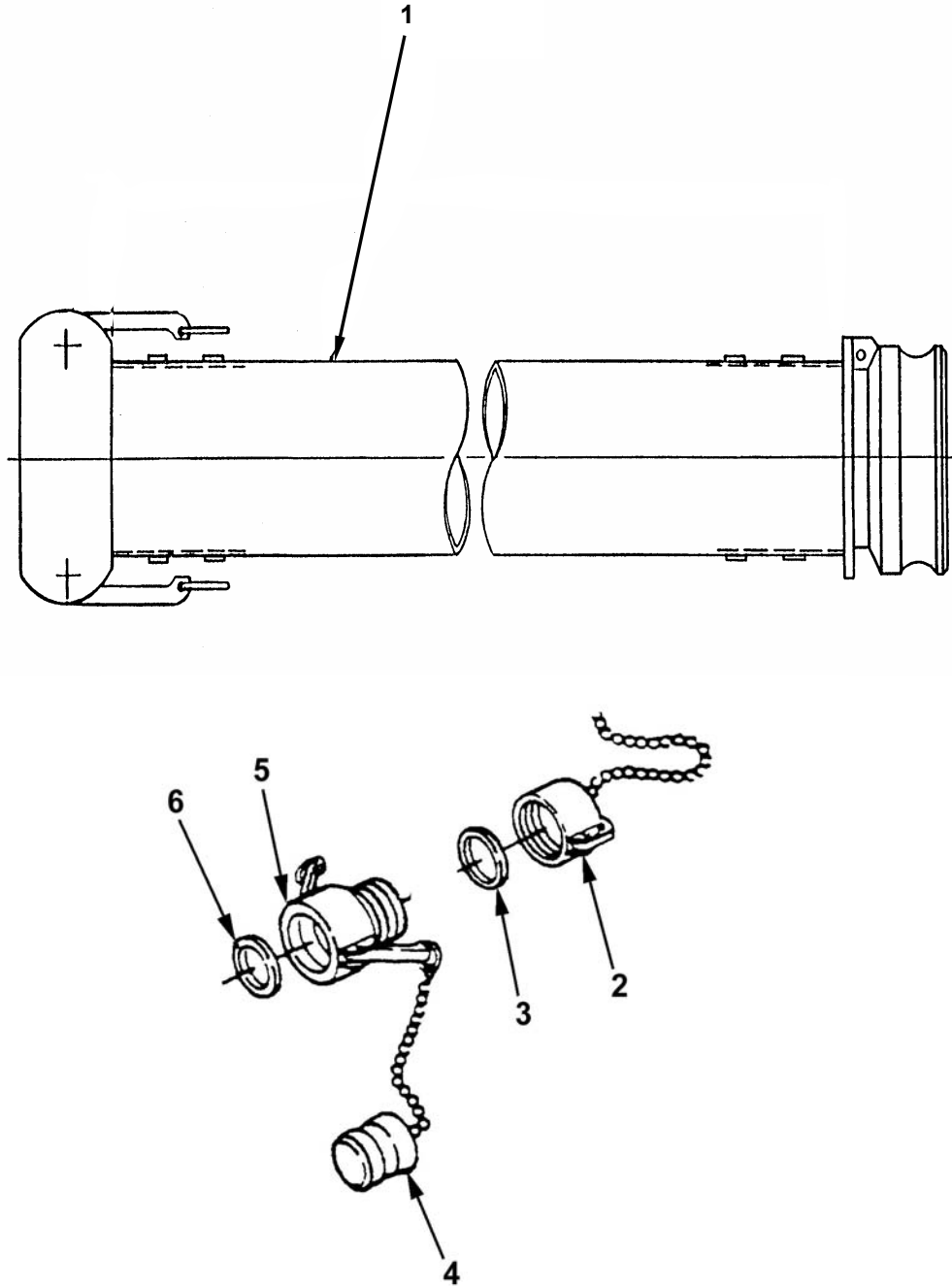

Figure 2. Hose Assembly.

| (1) | (2) | (3) | (4) | (5) | (6) | (7) |
|----------|----------|------------------|-------|--------------|--|-----|
| ITEM NO. | SMR CODE | NSN | CAGEC | PART NUMBER | DESCRIPTION AND USABLE ON CODE (UOC) | QTY |
| | | | | | GROUP 01 | |
| | | | | | FIGURE 2. HOSE ASSEMBLY | |
| 1 | XDOZZ | 4720-01-163-4684 | 97403 | 13225E9135-2 | HOSE ASSEMBLY, NONMETALLIC, SUCTION, 2IN X 20 FT LONG UOC: FGC, FGK..... | 2 |
| 1 | XDOZZ | 4720-01-163-5089 | 97403 | 13225E9135-4 | HOSE ASSEMBLY, NONMETALLIC MALE/FEMALE CAM LOCK ENDS, 4IN X 20 FT LONG UOC: EZR, FGL..... | 2 |
| 2 | XDOZZ | 4730-00-649-9100 | 96906 | MS27028-11 | CAP, QUICK DISCONNECT, 2IN UOC: FGC, FGK..... | 2 |
| 2 | XDOZZ | 4730-00-640-6156 | 96906 | MS27028-17 | CAP, QUICK DISCONNECT, 4IN UOC: EZR, FGL..... | 2 |
| 3 | XDOZZ | 5330-00-612-2414 | 96906 | MS27030-6 | .GASKET UOC: FGC, FGK..... | 2 |
| 3 | XDOZZ | 5330-00-899-4509 | 96906 | MS27030-9 | .GASKET UOC: EZR, FGL..... | 2 |
| 4 | XDOZZ | 4730-00-915-5127 | 58536 | AA59326X16 | PLUG, QUICK DISCONNECT, 2IN UOC: FGC, FGK..... | 2 |
| 4 | XDOZZ | 4730-00-640-6188 | 58536 | AA59326X19 | PLUG, QUICK DISCONNECT, 4IN UOC: EZR, FGL..... | 2 |
| 5 | XDOZZ | 4730-00-203-1010 | 96906 | MS27026-9 | COUPLING HALF, QUICK CONNECT, 1-1/2 IN CAM-LOCK FEMALE BY 1-1/2 IN NPT MALE | 1 |
| 6 | XDOZZ | 5330-00-360-0595 | 96906 | M27030-5 | .GASKET..... | 1 |

END OF FIGURE

OPERATOR, UNIT, AND DIRECT SUPPORT MAINTENANCE

TANK, FABRIC, COLLAPSIBLE, WATER, 3,000 AND 5,000 GALLONS, SEMI-TRAILER MOUNTED

FILLER/DISCHARGE ASSEMBLY

REPAIR PARTS LIST

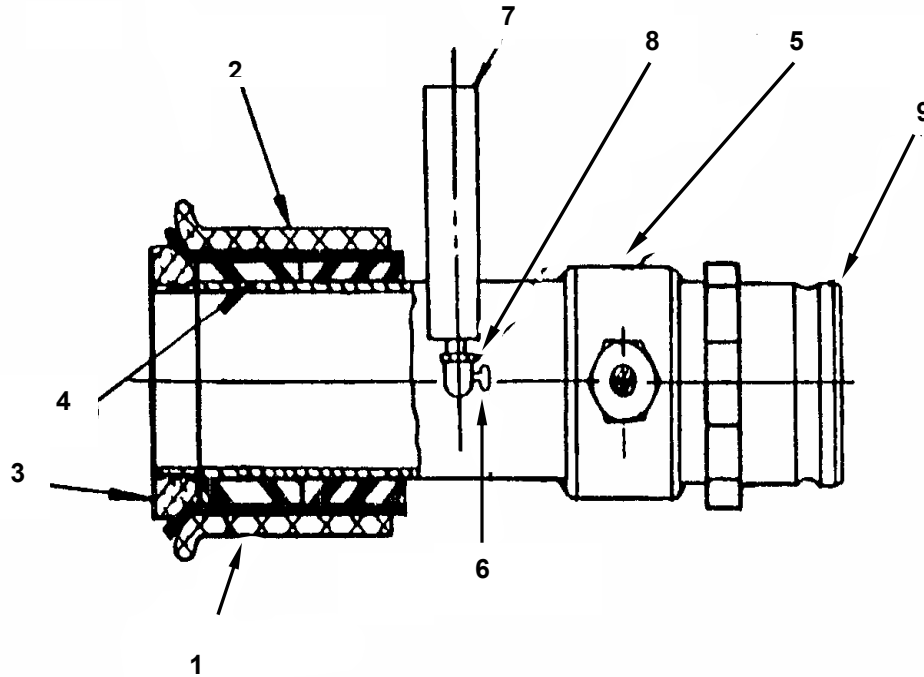

Figure 3. Filler/Discharge Assembly.

| (1) | (2) | (3) | (4) | (5) | (6) | (7) |
|----------|----------|------------------|-------|----------------------|---|-----|
| ITEM NO. | SMR CODE | NSN | CAGEC | PART NUMBER | DESCRIPTION AND USABLE ON CODE (UOC) | QTY |
| | | | | | GROUP 02 FILLER/DISCHARGE ASSEMBLY | |
| | | | | | FIGURE 3. FILLER/DISCHARGE ASSEMBLY | |
| | XAOOO | | 00333 | NPN-FIL/DIS ASSEMBLY | FILL/DISCHARGE ASSY UOC: FGK, FGL..... | 1 |
| | XAOOO | | 81349 | M53055FIL/DI S | FILL/DISCHARGE ASSY UOC: EZR, FGC..... | 1 |
| 1 | XDOZZ | | 00333 | 5332.6521 | .CLAMP, 4IN, BOTTOM UOC: EZR, FGC..... | 1 |
| 1 | XBOZZ | | 05476 | HC-274-2 | .PIPE, CLAMP 4 INCH UOC: FGK, FGL..... | 1 |
| 2 | XDOZZ | | 00333 | 5332.0311 | .CLAMP, 4 IN, TOP UOC: EZR, FGC..... | 1 |
| 2 | XBOZZ | | 05476 | HC-274-3 | .PIPE, CLAMP 4 INCH UOC: FGK, FGL..... | 1 |
| 3 | XDOZZ | | 00333 | 5332.3172 | .FLANGE, 4 IN, INSIDE UOC: EZR, FGC..... | 1 |
| 3 | XBOZZ | | 05476 | HB-187 | .FLANGE, PIPE, INSIDE UOC: FGK, FGL..... | 1 |
| 4 | XDOZZ | | 00333 | 5332.6011 | .ADAPTER, 4 IN, RUBBER UOC: EZR, FGC..... | 2 |
| 4 | XBOZZ | | 05476 | RB-107-2 | .ADAPTER, RUBBER 4 INCH UOC: FGK, FGL..... | 2 |
| 5 | XDOZZ | | 00333 | 5332.0552 | .VALVE, GATE, 4 IN UOC: EZR, FGC..... | 1 |
| 5 | XBOZZ | | 05476 | HD-545-8 | .VALVE, GATE, 4 IN UOC: FGK, FGL..... | 1 |
| 6 | XDOZZ | 4820-01-306-3076 | 39428 | 4793K52 | .COCK, DRAIN..... | 1 |
| 7 | PAOZZ | 6685-01-360-1874 | 39428 | 4089K33 | .GAGE, PRESSURE, DIAL 0 TO 15 PSI..... | 1 |
| 8 | PBOZZ | 4730-00-277-5553 | 96906 | MS51952-2 | .ELBOW, PIPE..... | 1 |
| 9 | PAOZZ | 4730-00-840-0796 | 58536 | AA59326I19 | .COUPLING HALF, QUICK DISCONNECT, FEMALE 4 IN NPT UOC: FGK, FGL..... | 1 |
| 9 | XDOZZ | 4730-00-840-0797 | 96906 | MS27022-17 | .COUPLING HALF, QUICK DISCONNECT, FEMALE 4 IN NPT UOC: EZR, FGC..... | 1 |

| (1) | (2) | (3) | (4) | (5) | (6) | (7) |
|----------|----------|------------------|-------|-------------|--|-----|
| ITEM NO. | SMR CODE | NSN | CAGEC | PART NUMBER | DESCRIPTION AND USABLE ON CODE (UOC) | QTY |
| 10 | PBOZZ | 4730-00-193-2711 | 96906 | MS51846-42 | .NIPPLE, PIPE (NOT ILLUSTRATED) UOC: FGK, FGL..... | 1 |

END OF FIGURE

OPERATOR, UNIT, AND DIRECT SUPPORT MAINTENANCE

TANK, FABRIC, COLLAPSIBLE, WATER, 3,000 AND 5,000 GALLONS SEMI-TRAILER MOUNTED

EMERGENCY REPAIR ITEMS

REPAIR PARTS LIST

1
2 THRU 19

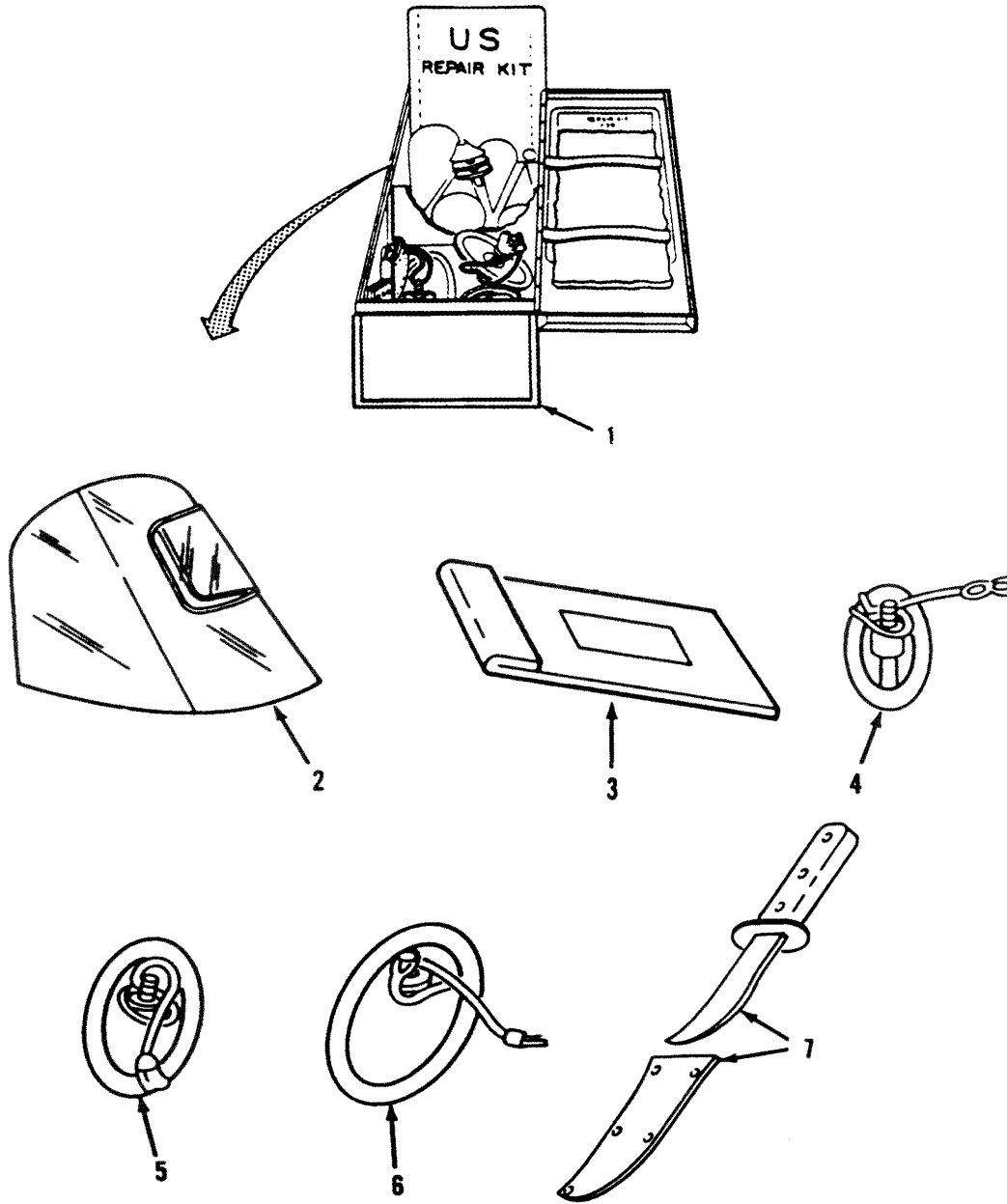

Figure 4. Emergency Repair Items (Sheet 1 of 2).

OPERATOR, UNIT, AND DIRECT SUPPORT MAINTENANCE

TANK, FABRIC, COLLAPSIBLE, WATER, 3,000 AND 5,000 GALLONS, SEMI-TRAILER MOUNTED

EMERGENCY REPAIR ITEMS

REPAIR PARTS LIST - Continued

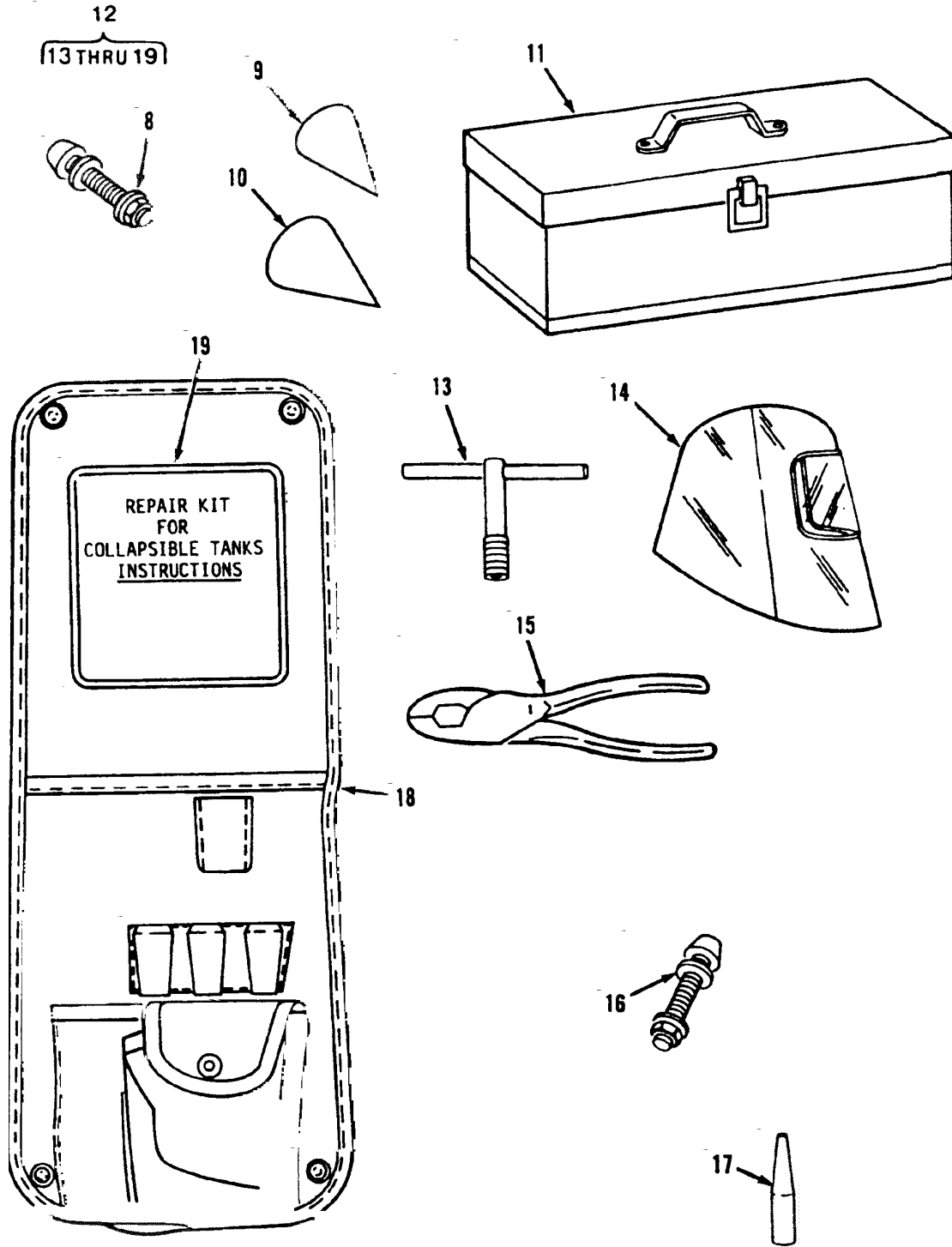

Figure 4. Emergency Repair Items (Sheet 2 of 2).

| (1) | (2) | (3) | (4) | (5) | (6) | (7) |
|----------|----------|------------------|-------|---------------------------|---|-----|
| ITEM NO. | SMR CODE | NSN | CAGEC | PART NUMBER | DESCRIPTION AND USABLE ON CODE (UOC) | QTY |
| | | | | | GROUP 03, EMERGENCY REPAIR ITEMS | |
| | | | | | FIGURE 4. EMERGENCY REPAIR KITS, TYPE I AND II | |
| 1 | XDOZZ | 8110-00-856-6246 | 81349 | MIL-R-52255 | REPAIR KIT, TANK, FABRIC, COLLAPSIBLE, TYPE II..... | 1 |
| 2 | XDOZZ | 8110-01-120-7824 | 81349 | M52255 FIG. 11 ITEM 11 | .HOOD, FLEXIBLE..... | 1 |
| 3 | XDOZZ | 7610-01-128-1852 | 81349 | X-3066 | .SHEET, TECHNICAL..... | 1 |
| 4 | XDOZZ | 5342-00-720-8864 | 81349 | 13202E2870-1 | .PATCH, MECHANICAL..... FL, 3 IN | 2 |
| 5 | XDOZZ | 5340-00-720-8863 | 81349 | 13202E2870-2 | .PATCH, MECHANICAL..... FL, 5 IN | 2 |
| 6 | XDOZZ | 5340-00-720-8858 | 81349 | 13202E2870-3 | .PATCH, MECHANICAL..... FL, 7.5 IN | 2 |
| 7 | XDOZZ | 5430-01-123-3082 | 81349 | M52255 FIG. 8 | .KNIFE AND SHEATH ASSY. | 1 |
| 8 | XDOZZ | 5430-01-245-5983 | 81349 | M52255 FIG. 5- TYPEII | .PATCH ASSEMBLY..... MECHANICAL, 2 IN | 2 |
| 9 | XDOZZ | 5510-01-412-0264 | 81349 | M52255 FIG.3-1 ½ | .PLUG, WOOD, 1.5 IN..... | 2 |
| 10 | XDOZZ | 5510-01-119-5995 | 81349 | X-3059-2 | .PLUG, WOOD, 2 IN..... | 2 |
| 11 | XDOZZ | 5430-01-248-1662 | 81349 | M52255 FIG. 10 | .CONTAINER, REPAIR KIT... | 1 |
| 12 | XDOZZ | 8110-00-856-6244 | 97403 | 5-14-679-1 | .REPAIR KIT, TANK, FABRIC, COLLAPSIBLE, TYPE I..... | 1 |
| 13 | XDOZZ | 5430-01-114-4597 | 81349 | M52255 FIG. 2 | ..ROTARY CUTTER, WRENCH AND INSERT TOOL ASSEMBLY..... | 1 |
| 14 | XDOZZ | 8110-01-120-7824 | 81349 | M52255 FIG. 11 ITEM 11 | ..HOOD, FLEXIBLE..... | 1 |
| 15 | XDOZZ | 5110-01-119-5392 | 81349 | X-3064-6 | ..PLIERS, LINEMAN, 8 IN..... TYPE IX, CLASS I, STYLE A. | 1 |
| 16 | XDOZZ | 5430-01-114-4598 | 81349 | M52255 FIG. 4 | ..PATCH ASSEMBLY, MECHANICAL, ¾ IN..... | 6 |
| 17 | XDOZZ | 5510-01-115-0893 | 81349 | M52255 FIG. 3 5/8 | ..PLUG, WOOD, 5/8 IN..... | 3 |

| (1) | (2) | (3) | (4) | (5) | (6) | (7) |
|----------|----------|------------------|-------|---------------|--------------------------------------|-----|
| ITEM NO. | SMR CODE | NSN | CAGEC | PART NUMBER | DESCRIPTION AND USABLE ON CODE (UOC) | QTY |
| 18 | XDOZZ | 5430-01-114-5392 | 81349 | M52255 FIG. 1 | ..POUCH, REPAIR KIT..... | 1 |
| 19 | XDOZZ | 7610-01-122-3771 | 81349 | X-3062 | ..SHEET, TECHNICAL..... | 1 |

END OF FIGURE

OPERATOR, UNIT, AND DIRECT SUPPORT MAINTENANCE

TANK, FABRIC, COLLAPSIBLE, WATER, 3,00 AND 5,000 GALLONS, SEMI-TRAILER MOUNTED

TIE DOWN ASSEMBLY

REPAIR PARTS LIST

1

2 - 10

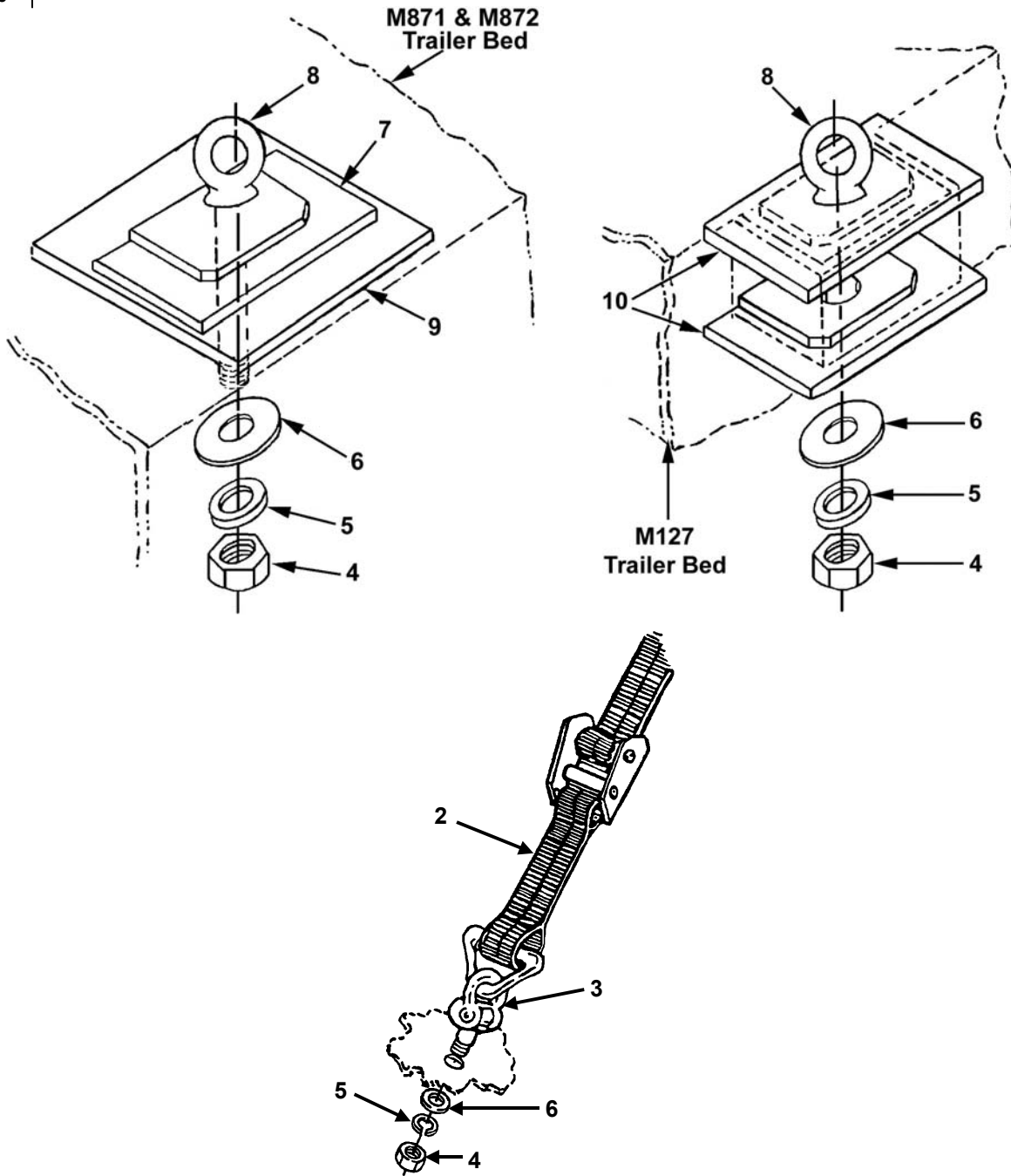

Figure 5. Tie Down Assembly.

| (1) | (2) | (3) | (4) | (5) | (6) | (7) |
|----------|----------|-----|-------|-------------------|--|-----|
| ITEM NO. | SMR CODE | NSN | CAGEC | PART NUMBER | DESCRIPTION AND USABLE ON CODE (UOC) | QTY |
| | | | | | GROUP 04 | |
| | | | | | FIGURE 5. TIE DOWN ASSEMBLY | |
| 1 | XAOOO | | 81349 | M53055TIEDOWN KIT | TIE DOWN KIT UOC: EZR..... | 1 |
| 1 | XAOOO | | 00333 | NPN-TIE DOWN KIT | TIE DOWN KIT UOC: FGC..... | 1 |
| 1 | XAOOO | | 05476 | FCD64631 | TIE DOWN ASSEMBLY UOC: FGL..... | 1 |
| 1 | XAOOO | | 05476 | FCD64632 | TIE DOWN ASSEMBLY UOC: FGK..... | 1 |
| 2 | XDOZZ | | 00333 | 5332.0539 | .TIE DOWN, 2 IN STRAP, BEIGE, 26 FT, WITH 2 LOCKING TAKE-UP RATCHETS UOC: EZR, FGC..... | 5 |
| 2 | XDOZZ | | 05476 | FCD64631-1 | .BELT, TIE DOWN ASSY, 3 IN X 33 FT LONG, BEIGE UOC: FGL..... | 4 |
| 2 | XDOZZ | | 05476 | FCD64632-1 | .BELT, TIE DOWN ASSY, 2 IN X 33 FT LONG, BEIGE UOC: FGK..... | 4 |
| 3 | XDOZZ | | 00333 | 5332.0907 | .SHACKLE, 5/8 IN UOC: EZR, FGC..... | 8 |
| 3 | XDOZZ | | 05476 | FCD64632-3 | .SHACKLE, 5/8 IN UOC: FGK..... | 8 |
| 3 | XDOZZ | | 05476 | FCD64631-3 | .SHACKLE, 5/8 IN UOC: FGL..... | 8 |
| 4 | XDOZZ | | 00333 | 5332.7078 | .NUT, HEX, 5/8 IN UOC: EZR, FGC..... | 8 |
| 5 | XDOZZ | | 00333 | 5332.7088 | .WASHER, LOCK, 5/8 IN UOC: EZR, FGC..... | 8 |
| 5 | XDOZZ | | 05476 | FCD64632-6 | .WASHER, LOCK, 5/8 IN UOC: FGK..... | 8 |
| 5 | XDOZZ | | 05476 | FCD64631-6 | .WASHER, LOCK, 5/8 IN UOC: FGL..... | 8 |

| (1) | (2) | (3) | (4) | (5) | (6) | (7) |
|----------|----------|-----|-------|-------------|---|-----|
| ITEM NO. | SMR CODE | NSN | CAGEC | PART NUMBER | DESCRIPTION AND USABLE ON CODE (UOC) | QTY |
| 6 | XDOZZ | | 81348 | FF-W-92B | .WASHER, FLAT, 5/8 IN UOC: EZR, FGC..... | 8 |
| 6 | XDOZZ | | 05476 | FCD64632-5 | .WASHER, FLAT, 5/8 IN UOC: FGK..... | 8 |
| 6 | XDOZZ | | 05476 | FCD64631-5 | .WASHER, FLAT, 5/8 IN UOC: FGL..... | 8 |
| 7 | XDOZZ | | 00333 | 5332.0140 | .PLATE, RETAINER, TOP UOC: EZR, FGC..... | 8 |
| 7 | XDOZZ | | 05476 | FCD64632-8 | .PLATE, RETAINER, TOP UOC: FGK..... | 8 |
| 7 | XDOZZ | | 05476 | FCD64631-4 | .PLATE, RETAINER, TOP UOC: FGL..... | 8 |
| 8 | XDOZZ | | 00333 | 5332.7089 | .EYEBOLT, 5/8 IN UOC: EZR, FGC..... | 8 |
| 8 | XDOZZ | | 05476 | FCD64632-7 | .EYEBOLT WITH HEX NUT, 5/8 IN UOC: FGK..... | 8 |
| 8 | XDOZZ | | 05476 | FCD64631-7 | .EYEBOLT WITH HEX NUT, 5/8 IN UOC: FGL..... | 8 |
| 9 | XDOZZ | | 00333 | 5332.0499 | .PLATE, RETAINER, BTM UOC: EZR, FGC..... | 8 |
| 9 | XDOZZ | | 05476 | FCD64632-8 | .PLATE, RETAINER, BTM UOC: FGK..... | 8 |
| 9 | XDOZZ | | 05476 | FCD64631-4 | .PLATE, RETAINER, BTM UOC: FGL..... | 8 |
| 10 | XDOZZ | | 05476 | FCD64632-4 | .PLATE, POCKET UOC: FGK..... | 16 |
| 10 | XDOZZ | | 05476 | 5332.0511 | .PLATE, POCKET UOC: FGC..... | 16 |

END OF FIGURE

OPERATOR, UNIT AND DIRECT SUPPORT MAINTENANCE
TANK, FABRIC, COLLAPSIBLE, WATER, 3,000 AND 5,000 GALLONS, SEMI-TRAILER MOUNTED
ACCESSORIES
REPAIR PARTS LIST

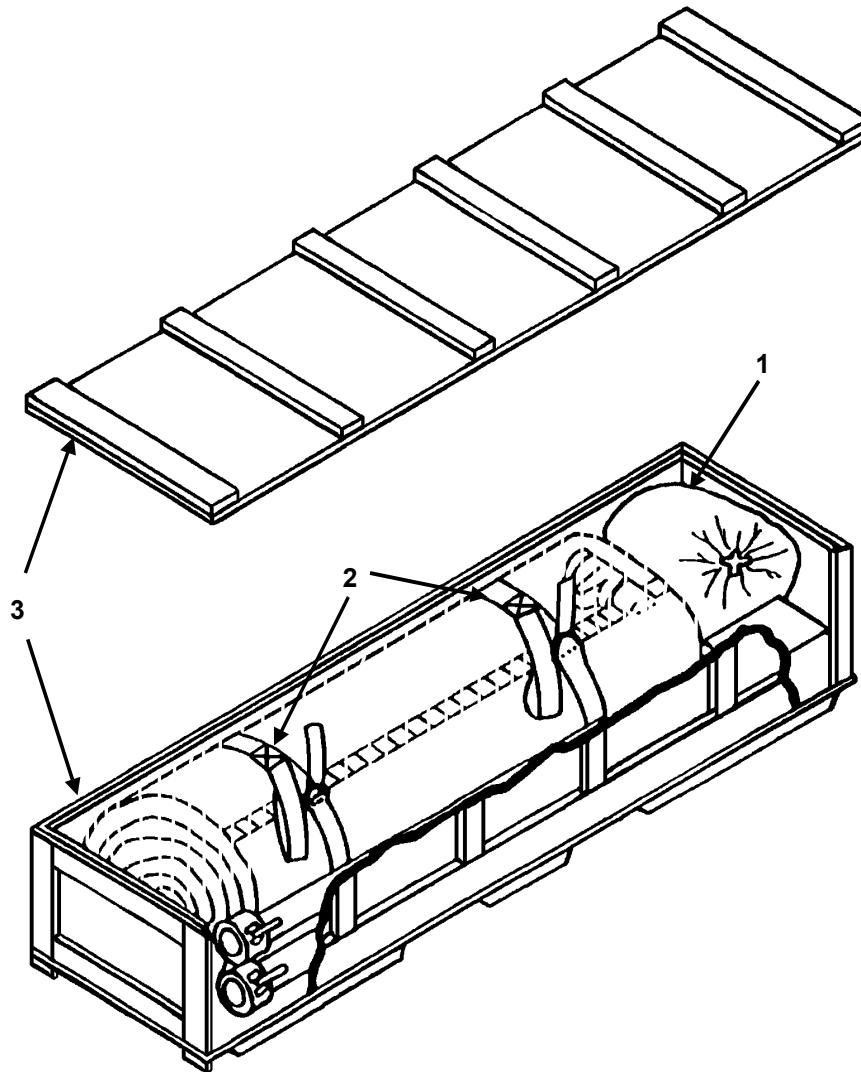

Figure 6. Accessories.

| (1) | (2) | (3) | (4) | (5) | (6) | (7) |
|----------|----------|-----|-------|------------------|--|-----|
| ITEM NO. | SMR CODE | NSN | CAGEC | PART NUMBER | DESCRIPTION AND USABLE ON CODE (UOC) | QTY |
| | | | | | GROUP 05 ACCESSORIES | |
| | | | | | FIGURE 6. ACCESSORIES | |
| 1 | XDOZZ | | 81349 | M53055A-II/BAG | BAG, DUFFEL, ACCESSORIES UOC: EZR..... | 1 |
| 1 | XDOZZ | | 00333 | 5332.0929 | BAG, DUFFEL, ACCESSORIES UOC: FGC..... | 1 |
| 1 | XDOZZ | | 05476 | FCC-64629 | BAG, DUFFEL ACCESSORIES UOC: FGK..... | 1 |
| 1 | XDOZZ | | 05476 | FCC-64623 | BAG, DUFFEL, ACCESSORIES UOC: FGL..... | 1 |
| 2 | XDOZZ | | 05476 | FCC-64630-1 | SLING, CARRYING UOC: FGC, FGK, FGL..... | 1 |
| 2 | XDOZZ | | 81349 | M53055A-II/SLING | SLING, CARRYING UOC: EZR..... | 1 |
| 3 | XDOZZ | | 81349 | M53055A-II/BOX | BOX, SHIPPING UOC: EZR..... | 1 |

END OF FIGURE

END OF WORK PACKAGE

UNIT AND DIRECT SUPPORT MAINTENANCE

TANK, FABRIC, COLLAPSIBLE, WATER, 3,000 AND 5,000 GALLONS, SEMI-TRAILER MOUNTED

NATIONAL STOCK NUMBER INDEX

| STOCK NUMBER | FIG. | ITEM | STOCK NUMBER | FIG. | ITEM |
|------------------|------|------|--------------|------|------|
| 4730-00-193-2711 | 3 | 10 | | | |
| 4730-00-203-1010 | 2 | 5 | | | |
| 4730-00-277-5553 | 3 | 8 | | | |
| 5330-00-360-0595 | 2 | 6 | | | |
| 5306-00-469-5339 | 1 | 12 | | | |
| 5330-00-612-2414 | 2 | 3 | | | |
| 4730-00-640-6156 | 2 | 2 | | | |
| 4730-00-640-6188 | 2 | 4 | | | |
| 4730-00-649-9100 | 2 | 2 | | | |
| 5342-00-720-8858 | 4 | 6 | | | |
| 5342-00-720-8863 | 4 | 5 | | | |
| 5342-00-720-8864 | 4 | 4 | | | |
| 4730-00-840-0796 | 1 | 9 | | | |
| | 3 | 9 | | | |
| 4730-00-840-0797 | 1 | 9 | | | |
| | 3 | 9 | | | |
| 8110-00-856-6244 | 4 | 12 | | | |
| 8110-00-856-6246 | 4 | 1 | | | |
| 5330-00-899-4509 | 2 | 3 | | | |
| 4730-00-915-5127 | 2 | 4 | | | |
| 5430-01-114-4597 | 4 | 13 | | | |
| 5430-01-114-4598 | 4 | 16 | | | |
| 5430-01-114-5392 | 4 | 18 | | | |
| 5510-01-115-0893 | 4 | 17 | | | |
| 5410-01-119-5392 | 4 | 15 | | | |
| 5510-01-119-5995 | 4 | 10 | | | |
| 5430-01-120-7823 | 1 | - | | | |
| 8110-01-120-7824 | 4 | 2 | | | |
| | 4 | 14 | | | |
| 7610-01-122-3771 | 4 | 19 | | | |
| 5430-01-123-3082 | 4 | 7 | | | |
| 7610-01-128-1852 | 4 | 3 | | | |
| 5310-01-163-0602 | 1 | 11 | | | |
| 4720-01-163-4684 | 2 | 1 | | | |
| 4720-01-163-5089 | 2 | 1 | | | |
| 5430-01-181-4071 | 1 | - | | | |
| 5430-01-245-5983 | 4 | 8 | | | |
| 5430-01-248-1662 | 4 | 11 | | | |
| 4820-01-306-3076 | 3 | 6 | | | |
| 6685-01-360-1874 | 1 | 8 | | | |
| | 3 | 7 | | | |
| 5430-01-372-6900 | 1 | - | | | |
| 5430-01-372-6901 | 1 | - | | | |
| 5510-01-412-0264 | 4 | 9 | | | |

END OF WORK PACKAGE

UNIT AND DIRECT SUPPORT MAINTENANCE

TANK, FABRIC, COLLAPSIBLE, WATER, 3,000 AND 5,000 GALLONS, SEMI-TRAILER MOUNTED

PART NUMBER INDEX

| PART NUMBER | FIG. | ITEM | PART NUMBER | FIG. | ITEM |
|-----------------------|------|------|----------------------|------|------|
| AA59326I19 | 1 | 9 | MS27028-17 | 2 | 2 |
| | 3 | 9 | MS27030-5 | 2 | 6 |
| AA59326X16 | 2 | 4 | MS27030-6 | 2 | 3 |
| AA59326X19 | 2 | 4 | MS27030-9 | 2 | 3 |
| FCC-64623 | 6 | 1 | MS51846-42 | 3 | 10 |
| FCC-64629 | 6 | 1 | MS51952-2 | 3 | 8 |
| FCC-64630-1 | 6 | 2 | NAS1149D1063K | 1 | 11 |
| FCD64631 | 5 | 1 | NPN-FIL/DIS ASSEMBLY | 3 | |
| FCD64631-1 | 1 | 2 | M53055TIEDOWNKIT | 5 | 1 |
| | 5 | 2 | P-800 | 1 | 15 |
| FCD64631-3 | 5 | 3 | PD62783-3000 | 1 | |
| FCD64631-4 | 5 | 7 | PD62783-4750 | 1 | |
| | 5 | 9 | RB-107-2 | 3 | 4 |
| FCD64631-5 | 5 | 6 | RE230 | 1 | 1 |
| FCD64631-6 | 5 | 5 | RE231 | 1 | 1 |
| FCD64631-7 | 5 | 8 | X-3059-2 | 4 | 10 |
| FCD64632 | 5 | 1 | X-3062 | 4 | 19 |
| FCD64632-1 | 1 | 2 | X-3064-6 | 4 | 15 |
| | 5 | 2 | X-3066 | 4 | 3 |
| FCD64632-3 | 5 | 3 | 13202E2870-1 | 4 | 4 |
| FCD64632-4 | 5 | 10 | 13202E2870-2 | 4 | 5 |
| FCD64632-5 | 5 | 6 | 13202E2870-3 | 4 | 6 |
| FCD64632-6 | 5 | 5 | 13225E9135-2 | 2 | 1 |
| FCD64632-7 | 5 | 8 | 13225E9135-4 | 2 | 1 |
| FCD64632-8 | 5 | 7 | 4089K33 | 1 | 8 |
| | 5 | 9 | | 3 | 7 |
| FF-W-92B | 5 | 6 | 4793K52 | 3 | 6 |
| HB-187 | 3 | 3 | 5-14-679-1 | 4 | 12 |
| HC-270-2 | 1 | 6 | 5332.0140 | 5 | 7 |
| HC-270-3 | 1 | 5 | 5332.0198 | 1 | 5 |
| HC-273-3 | 1 | 10 | 5332.0311 | 3 | 2 |
| HC-274-2 | 3 | 1 | 5332.0312 | 1 | 10 |
| HC-274-3 | 3 | 2 | 5332.0499 | 5 | 9 |
| HC-439-1 | 1 | 3 | 5332.0511 | 5 | 10 |
| HC-439-2 | 1 | 14 | 5332.0539 | 1 | 2 |
| HC-440-1 | 1 | 13 | | 5 | 2 |
| HD-545-8 | 1 | 7 | | 1 | 3 |
| | 3 | 5 | | 1 | 4 |
| M52255 FIG. 1 | 4 | 18 | | 1 | 13 |
| M52255 FIG. 2 | 4 | 13 | | 1 | 14 |
| M52255 FIG. 3-1 1/2 | 4 | 9 | 5332.0552 | 1 | 7 |
| M52255 FIG. 3-5/8 | 4 | 17 | | 3 | 5 |
| M52255 FIG. 4 | 4 | 16 | 5332.0907 | 5 | 3 |
| M52255 FIG. 5-TYPEII | 4 | 8 | 5332.0929 | 6 | 1 |
| M52255 FIG. 8 | 4 | 7 | 5332.1141 | 1 | 15 |
| M52255 FIG. 10 | 4 | 11 | 5332.0539 | | |
| M52255 FIG. 11 ITEM11 | 4 | 2 | 5332.0546 | | |
| | 4 | 14 | 5332.0547 | | |
| M53055TIEDOWNKIT | 5 | 1 | 5332.0548 | | |
| | | | 5332.0550 | | |

| PART NUMBER | FIG. | ITEM | PART NUMBER | FIG. | ITEM |
|------------------|------|------|-------------|------|------|
| M53055A-II | 1 | 1 | 5332.3172 | 3 | 3 |
| M53055A-II/BAG | 6 | 1 | 5332.6011 | 3 | 4 |
| M53055A-II/BOX | 6 | 3 | 5332.6495 | 1 | 6 |
| M53055A-II/SLING | 6 | 2 | 5332.6521 | 3 | 1 |
| M53055FIL/DIS | 3 | | 5332.7078 | 5 | 4 |
| MIL-R-52255 | 4 | 1 | 5332.7088 | 5 | 5 |
| MS16208-141 | 1 | 12 | 5332.7089 | 5 | 8 |
| MS20726-9 | 2 | 5 | 90082 | 1 | 16 |
| MS27022-17 | 1 | 9 | 90084 | 1 | 16 |
| | 3 | 9 | 91093 | 1 | |
| MS27028-11 | 2 | 2 | 91094 | 1 | |

END OF WORK PACKAGE

**OPERATOR, UNIT, AND DIRECT SUPPORT MAINTENANCE MANUAL
(INCLUDING REPAIR PARTS AND SPECIAL TOOLS LIST)
TANK, FABRIC, COLLAPSIBLE, WATER, 3,000 AND 5,000 GALLONS, SEMI-TRAILER MOUNTED
COMPONENTS OF END ITEM (COEI) AND BASIC ISSUE ITEMS (BII) LISTS**

COMPONENTS OF END ITEM (COEI) AND BASIC ISSUE ITEMS (BII) LISTS

INTRODUCTION

Scope

This work package lists COEI and BII for the collapsible fabric water tank to help you inventory items for safe and efficient operation of the equipment.

General

The COEI and BII information is divided into the following lists:

Components of End Item (COEI). This list is for information purposes only and is not authority to requisition replacements. These items are part of the collapsible fabric water tank. As part of the end item, these items must be with the end item whenever it is issued or transferred between property accounts. Items of COEI are removed and separately packaged for transportation or shipment only when necessary. Illustrations are furnished to help you find and identify the items.

Basic Issue Items (BII). These essential items are required to place the collapsible fabric water tank in operation, operate it, and to do emergency repairs. Although shipped separately packaged, BII must be with the collapsible fabric water tank during operation and when it is transferred between property accounts. Listing these items is your authority to request/requisition them for replacement based on authorization of the end item by TOE/MTOE. Illustrations are furnished to help you find and identify the items.

Explanation of Columns in the COEI List and BII List

Column (1) — Illus Number. Gives you the number of the item illustrated.

Column (2) — National Stock Number (NSN). Identifies the stock number of the item to be used for requisitioning purposes.

Column (3) — Description, CAGEC, and Part Number. Identifies the Federal item name (in all capital letters) followed by a minimum description when needed. The stowage location of COEI and BII is also included in this column. The last line below the description is the CAGEC (commercial and Government entity code) (in parentheses) and the part number.

Column (4) — Usable On Code. When applicable, gives you a code if the item you need is not the same for different models of equipment. These codes are identified below:

| <u>Code</u> | <u>Used on</u> |
|-------------|--------------------|
| FGC | Model PD62783-3000 |
| FGK | Model 91093 |
| EZR | Model PD62783-4750 |
| FGL | Model 91094 |

Column (5) — Unit of Measure (U/M). Indicates the physical measurement or count of the item as issued per the National Stock Number shown in column (2).

Column (6) — Qty Rqr. Indicates the quantity required.

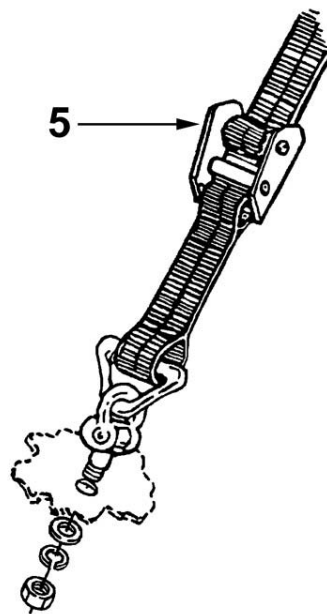
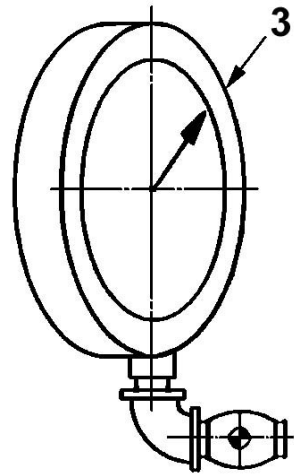
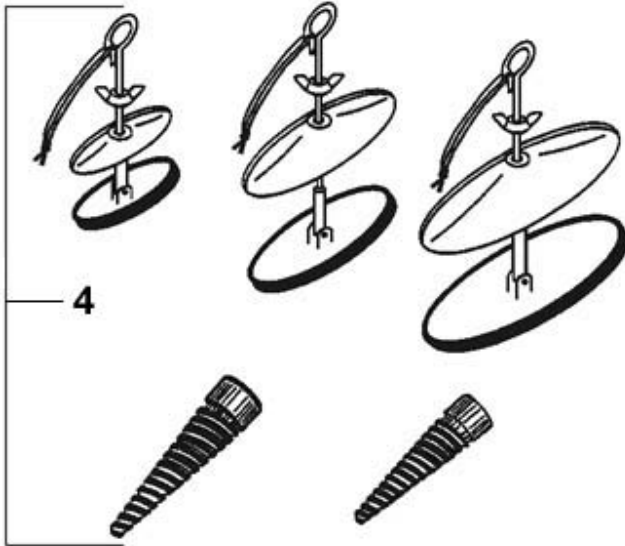
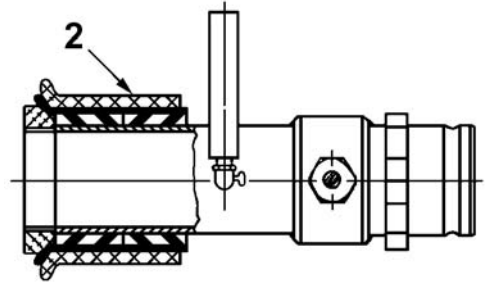
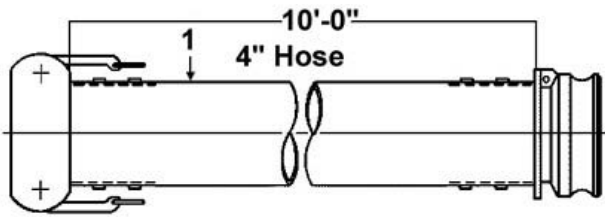

Table 1. Components of End Items List.

| (1) ILLUS NUMBER | (2) NATIONAL STOCK NUMBER (NSN) | (3) DESCRIPTION, CAGEC AND PART NUMBER | (4) USABLE ON CODE | (5) U/M | (6) QTY RQR |
|------------------------|--|---|-----------------------------|------------|-------------------|
| 1 | 4720-01-163-4684 | Hose Assembly, 2 In X 20 Ft (97403) 13225E9135-2 | FGC, FGK | EA | 1 |
| 1 | 4720-01-163-5089 | Hose Assembly, 4 In X 20 Ft (97403) 13225E9135-4 | EZR, FGL | EA | 1 |
| 2 | | Filler/Discharge Assembly (81349) M53055FIL/DIS | EZR,FGL | EA | 1 |
| 2 | | Filler/Discharge Assembly (00333) NPN-FIL/DIS Assembly | FGC, FGK | EA | 1 |
| 3 | 6685-01-360-1874 | Pressure Gage (39428) 4089K33 | EZR, FGC FGK, FGL | EA | 1 |
| 4 | 8110-00-856-6246 | Emergency Repair Kit (81349) MIL-R-52255 | EZR, FGC, FGK, FGL | EA | 1 |
| 5 | | Belt, Tie Down Assembly (05476) FCD64631-1 | FGL | EA | 4 |
| 5 | | Tie-Down Assembly (05476) FCD64632 | FGK | EA | 2 |
| 5 | | Tie-down, 2 In by 26 Ft with Ratchets (05476) 5332.0539 | FGC EZR, | EA | 5 |
| 5 | | Tie-down Kit (81349) M53055TIEDOWNKIT | EZR | EA | 1 |

TM 10-5430-240-13&P

TECHNICAL MANUAL

OPERATOR, UNIT, AND DIRECT SUPPORT MAINTENANCE MANUAL
(INCLUDING REPAIR PARTS AND SPECIAL TOOLS LIST)

**TANK, FABRIC, COLLAPSIBLE, WATER, 3,000 AND
5,000 GALLONS, SEMI-TRAILER MOUNTED**

3,000 GALLONS

MODEL PD62783-3000 (EIC = ZJP) NSN 5430-01-181-4071
MODEL 91093 (EIC = ZFX) NSN 5430-01-372-6901

5,000 GALLONS

MODEL PD62783-4750 (EIC = ZJJ) NSN 5430-01-120-7823
MODEL 91094 (EIC = ZFY) NSN 5430-01-372-6900

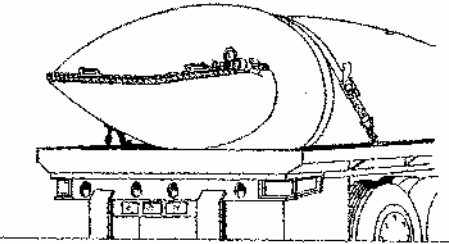

This manual supersedes TM 10-5430-212-13&P dated 15 September 1988 and TM 10-5430-212-13&P, dated 27 October 1986, including all changes.
DISTRIBUTION STATEMENT A. Approved for public release; distribution is unlimited.

HEADQUARTERS, DEPARTMENT OF THE ARMY
30 October 2001

1 →

Table 2. Basic Issue Items List.

| (1) ILLUS NUMBER | (2) NATIONAL STOCK NUMBER | (3) DESCRIPTION, CAGEC, AND PART NUMBER | (4) USABLE ON CODE | (5) U/M | (6) QTY RQR |
|------------------------|------------------------------------|--|--------------------------|------------|-------------------|
| 1 | | Technical Manual, Operator, Unit, and Direct Support Maintenance, Collapsible Fabric Water Tank, 3,000 and 5,000 Gallon TM10-5430-240-13&P | | EA | 1 |

END OF WORK PACKAGE

**OPERATOR, UNIT, AND DIRECT SUPPORT MAINTENANCE MANUAL
(INCLUDING REPAIR PARTS AND SPECIAL TOOLS LIST)
TANK, FABRIC, COLLAPSIBLE, WATER, 3,000 AND 5,000 GALLONS, SEMI-TRAILER MOUNTED
ADDITIONAL AUTHORIZATION LIST**

ADDITIONAL AUTHORIZATION LIST (AAL)

INTRODUCTION

Scope

This work package lists additional items you are authorized for the support of the trailer mounted 3,000 and 5,000 gallon water tanks.

General

This list identifies items that do not have to accompany the 3,000 and 5,000 gallon water tanks and that do not have to be turned in with it. These items are all authorized to you by CTA, MTOE, TDA, or JTA.

Explanation of Columns in the AAL

Column (1) — National Stock Number (NSN). Identifies the stock number of the item to be used for requisitioning purposes.

Column (2) — Description, Commercial and Government Entity Code (CAGEC), and Part Number (P/N). Identifies the Federal item name (in all capital letters) followed by a minimum description when needed. The last line below the description is the CAGEC (in parentheses) and the part number.

Column (3) — Usable On Code. When applicable, gives you a code if the item you need is not the same for different models of equipment. These codes are identified below:

| <u>Code</u> | <u>Used on</u> |
|-------------|--------------------|
| FGC | Model PD62783-3000 |
| FGK | Model 91093 |
| EZR | Model PD62783-4750 |
| FGL | Model 91094 |

Column (4) — Unit of Measure (U/M). Indicates the physical measurement or count of the item as issued per the National Stock Number in column (1).

Column (5) — Qty Recm. Indicates the quantity recommended.

ADDITIONAL AUTHORIZED LIST ITEMS

Table 1. Additional Authorization List.

| (1) NATIONAL STOCK NUMBER | (2) DESCRIPTION, CAGEC, AND PART NUMBER | (3) USABLE ON CODE | (4) U/M | (5) QTY RECM |
|-------------------------------------|---|------------------------------|-------------------|------------------------|
| 4720-01-138-8986 | Hose (22-H-601), 2-inch, 20-ft length, (97403) 13225E9136-2 | FGC, FGK | ea | 1 |
| 4720-01-140-6288 | Hose 4-inch, 20-ft. length, (97403) 13225E9136-4 | EZR, FGL | ea | 1 |

| (1) NATIONAL STOCK NUMBER | (2) DESCRIPTION, CAGEC, AND PART NUMBER | (3) USABLE ON CODE | (4) U/M | (5) QTY RECM |
|------------------------------|--|-----------------------|------------|-----------------|
| | Water Hose 2.0" ID x 50' long | | | |
| | Gage Hose .25" ID x 50' long | | | |
| 4730-01-064-0560 | Reducer, Female to Male, Quick Disconnect, (58536) AA59326XI-1-9 | FGC, FGK | ea | 1 |
| 4730-00-951-3295 | Reducer, Quick Disconnect (96906) MS49000-5 | FGC | ea | 1 |
| 4730-01-192-1624 | Reducer, Female to Male, (96906) MS49002-9 | FGK | ea | 1 |
| 4730-01-109-0790 | Swivel Hose, (97403) 13225E9139-3 | FGC | ea | 1 |
| 4610-01-188-8198 | Nozzle Distribution, Potable Water (81718) 190-GW-5115 1-11/2 | FGC | ea | 1 |

END OF WORK PACKAGE

**OPERATOR, UNIT, AND DIRECT SUPPORT MAINTENANCE MANUAL
(INCLUDING REPAIR PARTS AND SPECIAL TOOLS LIST)
TANK, FABRIC, COLLAPSIBLE, WATER, 3,000 AND 5,000 GALLONS, SEMI-TRAILER MOUNTED
EXPENDABLE AND DURABLE ITEMS LIST**

EXPENDABLE AND DURABLE ITEMS LIST

INTRODUCTION

Scope

This work package lists expendable and durable items that you will need to operate and maintain the collapsible fabric water tank. This list is for information only and is not authority to requisition the listed items. These items are authorized to you by CTA 50-970, Expendable/Durable Items (Except Medical, Class V Repair Parts, and Heraldic Items), or CTA 8-100, Army Medical Department Expendable/Durable Items.

Explanations of Columns in the Expendable/Durable Items List

Column (1) — Item Number. This number is assigned to the entry in the list and is referenced in the narrative instructions to identify the item (e.g., Use brake fluid (item 5, WP 0098 00).).

Column (2) — Level. This column identifies the lowest level of maintenance that requires the listed item.

Column (3) — National Stock Number (NSN). This is the NSN assigned to the item which you can use to requisition it.

Column (4) — Item Name, Description, Commercial and Government Entity Code (CAGEC), and Part Number (P/N). This column provides the other information you need to identify the item.

Column (5) — Unit of Measure (U/M). This code shows the physical measurement or count of an item, such as gallon, dozen, gross, etc.

EXPENDABLE AND DURABLE ITEMS LIST

Table 1. Expendable and Durable Items List.

| (1) ITEM NUMBER | (2) LEVEL | (3) NATIONAL STOCK NUMBER | (4) ITEM NAME, DESCRIPTION, CAGE, AND PART NUMBER | (5) U/M |
|-----------------------|--------------|---------------------------------|---|------------|
| 1 | O | 5430-01-359-1078 | Repair Kit, Collapsible Fabric Tank and Drums (ROCTAD), (OPX05) D & A Fluid Elastomer | EA |
| 2 | O | 5120-00-243-9402 | Roller, Hand (81349) MIL-S-45179 | EA |
| 3 | O | 7930-00-985-6911 | Detergent, General Purpose (81349) MIL-D-16791 | GL |
| 4 | O | 7920-00-205-1711 | Rag, Wiping, Cotton And Cotton Synthetic (81349) A-A-531 | BE |
| 5 | O | 7930-00-240-7174 | Brush, Scrub (81349) HB1490-5 | EA |

| (1) ITEM NUMBER | (2) LEVEL | (3) NATIONAL STOCK NUMBER | (4) ITEM NAME, DESCRIPTION, CAGE, AND PART NUMBER | (5) U/M |
|-----------------------|--------------|---------------------------------|---|------------|
| 6 | O | 7510-00-015-0505 | Tape, Adhesive (2J209) 1-4M | RL |
| 7 | O | 5640-00-103-2254 | Tape, Duct (39428) 1791K70 | RL |

END OF WORK PACKAGE

**OPERATOR, UNIT, AND DIRECT SUPPORT MAINTENANCE MANUAL
(INCLUDING REPAIR PARTS AND SPECIAL TOOLS LIST)
TANK, FABRIC, COLLAPSIBLE, WATER, 3,000 AND 5,000 GALLONS, SEMI-TRAILER MOUNTED
TORQUE LIMITS**

TORQUE LIMITS

This work package provides general torque limits for fasteners. Special torque values are indicated in the maintenance procedures for applicable components. The general torque values given in this work package shall be used when specific torque values are not indicated in the maintenance procedures.

Torque Limits

Torque limits are listed in Table 1 for fasteners. Dry fasteners are defined as fasteners on which no lubricants are applied to the threads. Wet fasteners are defined as fasteners on which graphite or molly-disulphide greases or other extreme pressure lubricants are applied to the threads. Table 2 lists the minimum breakaway torque values for locknuts.

Table 1. General Torque Requirements for Dry Fasteners.

| Bolt/Screw Size | Torque Requirement in lb ft (N•m) | | | |
|--------------------|-----------------------------------|----------------|---------------------|----------------|
| | SAE Grade 1 or 2 | SAE Grade 5 | SAE Grade 6 or 7 | SAE Grade 8 |
| 1/4-20 UNC | 5 (7) | 8 (11) | 10 (14) | 12 (16) |
| 1/4-28 UNF | 7 (8) | 10 (14) | 12 (16) | 14 (19) |
| 5/16-18 UNC | 11 (15) | 17 (23) | 19 (26) | 24 (33) |
| 5/16-24 UNF | 13 (18) | 19 (26) | 23 (31) | 27 (37) |
| 3/8-16 UNC | 18 (24) | 31 (42) | 34 (46) | 44 (60) |
| 3/8-24 UNF | 20 (27) | 35 (47) | 42 (57) | 49 (66) |
| 7/16-14 UNC | 28 (38) | 49 (66) | 55 (75) | 70 (95) |
| 7/16-20 UNF | 30 (41) | 55 (75) | 67 (91) | 78 (106) |
| 1/2-13 UNC | 39 (53) | 75 (102) | 85 (115) | 105 (142) |
| 1/2-20 UNF | 41 (56) | 85 (115) | 102 (138) | 120 (163) |
| 9/16-12 UNC | 51 (69) | 110 (149) | 120 (163) | 155 (210) |
| 9/16-18 UNF | 55 (75) | 120 (163) | 145 (197) | 170 (231) |
| 5/8-11 UNC | 63 (85) | 150 (203) | 167 (226) | 210 (285) |
| 5/8-18 UNF | 95 (129) | 170 (231) | 205 (278) | 240 (325) |
| 3/4-10 UNC | 105 (142) | 270 (366) | 280 (380) | 375 (509) |
| 3/4-16 UNF | 115 (156) | 295 (400) | 357 (484) | 420 (570) |
| 7/8-9 UNC | 160 (217) | 395 (536) | 440 (597) | 605 (820) |
| 7/8-14 UNF | 175 (237) | 435 (590) | 555 (753) | 675 (915) |
| 1-8 UNC | 235 (319) | 590 (800) | 660 (895) | 910 (1234) |
| 1-14 UNF | 250 (339) | 660 (865) | 825 (1119) | 999 (1342) |
| 1-1/8-7 UNC | 350 (475) | 800 (1085) | 1000 (1356) | 1280 (1736) |
| 1-1/8-12 UNF | 400 (542) | 880 (1193) | 1050 (1424) | 1440 (1953) |
| 1-1/4-7 UNC | 500 (678) | 1080 (1464) | 1325 (1797) | 1820 (2468) |
| 1-1/4-12 UNF | 550 (746) | 1125 (1526) | 1325 (1797) | 1820 (2712) |
| 1-3/8-6 UNC | 660 (895) | 1460 (1980) | 1800 (2441) | 2380 (3227) |
| 1-3/8-12 UNF | 740 (1003) | 1680 (2278) | 1960 (2658) | 2720 (3688) |
| 1-1/2-6 UNC | 870 (1180) | 1940 (2631) | 2913 (3950) | 3160 (4285) |
| 1-1/2-12 UNF | 980 (1329) | 2200 (2983) | 3000 (4068) | 3560 (4827) |

*Torque given is for clean, dry threads. Reduce by 10% when engine oil is used as lubricant.

Table 2. Locknut Breakaway Torque Values**NOTE**

To determine the breakaway torque, thread the locknut onto screw or bolt until at least two threads are shown. The locknut shall not make contact with a mating part. Stop the locknut. The torque necessary to begin turning locknut again is the breakaway torque. Do not reuse locknuts that do not meet minimum breakaway torque.

| <u>Thread Size</u> | <u>Minimum Breakaway Torque</u> | |
|-------------------------------|--|---------------------|
| | <u>lb-in.</u> | <u>(N•m)</u> |
| 10-32 | 2.0 | (0.23) |
| 1/4-28 | 3.5 | (0.40) |
| 5/16-24 | 6.5 | (0.73) |
| 3/8-24 | 9.5 | (1.07) |
| 7/16-20 | 14.0 | (1.58) |
| 1/2-20 | 18.0 | (2.03) |
| 9/16-18 | 24.0 | (2.71) |
| 5/8-18 | 32.0 | (3.62) |
| 3/4-16 | 50.0 | (5.65) |
| 7/8-14 | 70.0 | (7.91) |
| 1-12 | 90.0 | (10.17) |
| 1-1/8-12 | 117.0 | (13.22) |

END OF WORK PACKAGE

**OPERATOR, UNIT, AND DIRECT SUPPORT MAINTENANCE MANUAL
(INCLUDING REPAIR PARTS AND SPECIAL TOOLS LIST)
TANK, FABRIC, COLLAPSIBLE, WATER, 3,000 AND 5,000 GALLONS, SEMI-TRAILER MOUNTED
MANDATORY REPLACEMENT PARTS LIST**

MANDATORY REPLACEMENT PARTS LIST

This work package includes a list of all mandatory replacement parts referenced in the task initial setups and procedures. These items must be replaced during maintenance, whether they have failed or not. This includes items based on usage intervals such as miles, time, rounds fired, etc.

MANDATORY REPLACEMENT PARTS LIST**Table 1. Mandatory Replacement Parts List.**

| ITEM NO. | PART NUMBER/ CAGEC | NSN | NOMENCLATURE | QTY |
|-----------------|-------------------------------|------------------|---------------------|------------|
| 1 | MS27030-5 (96906) | 5330-00-360-0595 | Gasket | 1 |
| 2 | MS27030-6 (96906) | 5330-00-612-2414 | Gasket | 2 |
| 3 | MS27030-9 (96906) | 5330-00-899-4509 | Gasket | 3 |

END OF WORK PACKAGE

GLOSSARY

ABBREVIATIONS

| | |
|------------|--|
| AAL..... | Additional Authorization List |
| Assy..... | Assembly |
| BII..... | Basic Issue Items |
| bu..... | Bundle |
| °C..... | Degree Celsius |
| CAGEC..... | Commercial and Government Entity Code |
| COEI..... | Components of End Item |
| EIR..... | Equipment Improvement Recommendation |
| ESC..... | Equipment Serviceable Criteria |
| °F..... | Degree Fahrenheit |
| Fed..... | Federal |
| gl..... | Gallon |
| Illus..... | Illustration |
| MTOE..... | Modified Table of Organization and Equipment |
| MWO..... | Modification Work Order |
| NSN..... | National Stock Number |
| PMCS..... | Preventive Maintenance Checks and Services |
| QA/QC..... | Quality Assurance/Quality Control |
| Qty..... | Quantity |
| Rqr..... | Required |
| Spec..... | Specification |
| TAMMS..... | The Army Maintenance Management System |
| TMDE..... | Test, Measurement, and Diagnostic Equipment |
| U/M..... | Unit of Measure |

DEFINITIONS OF TERMS

A

APPROVED - Permitted to be used for a specific purpose by the person or group who is authorized to grant approval.

ASSEMBLY - A combination of parts that may be taken apart without destruction, which has no application or use of its own but is needed for the completeness of a more complex item with which it is combined, or to which it is attached.

C

COMPONENT - A part or a combination of parts, which together accomplish a function.

E

EXPENDABLE - An item that is not repairable and is discarded if damaged.

EXPOSURE - Being in the presence of something, or in contact with something. Skin is exposed to cleaning solvent when the solvent contacts the skin during cleaning operations.

L

LEGIBLE - Capable of being read. A legible nameplate can be read; an illegible plate cannot.

M

MALFUNCTION - Occurs when a unit fails to operate normally.

MANUFACTURER - Company which makes an item or piece of equipment for sale.

MATERIEL - Equipment, apparatus, and supplies of an organization, such as an army.

R

RECOMMENDATIONS - Suggestions for change; advice given usually to make an improvement.

REQUIRE - To demand or need.

S

SCOPE - The extent of an activity or concept; the amount of information covered as in a book.

SOLVENT - A liquid that can dissolve another substance.

T

TORQUE - Force around an axis. It produces a rotary or twisting motion, and is measured in foot-pounds (ft-lb) or Newton-meters (N•m).

V

VENTILATE - To provide with a source of fresh or uncontaminated air.

VISUAL - Visible; detected by the unaided eye.

INDEX

| <u>Subject</u> | <u>WP Sequence No. - Page No.</u> |
|--|-----------------------------------|
| A | |
| Abbreviations | Glossary-1 |
| Additional Authorization List..... | 0033 00-1 |
| Administrative Storage | 0022 00-4 |
| Assembly and Preparation for Use | 0005 00-1 |
| B | |
| Basic Issue Items (BII) Lists, Components of End Item (COEI) and | 0032 00-1 |
| C | |
| Characteristics, Capabilities, and Features, Equipment | 0002 00-1 |
| Clamp Assembly, Inspection, Repair and Replacement..... | 0018 00-1 |
| Collapsible Water Tank Theory of Operation..... | 0003 00-1 |
| Common Tools and Equipment | 0013 00-1, 0023 00-1 |
| Components, Description and Use of Major | 0004 00-1 |
| Components, Location and Description of | 0002 00-1 |
| Components of End Item (COEI) and Basic Issue Items (BII) Lists | 0032 00-1 |
| Correction of Deficiencies | 0005 00-6 |
| Corrosion Prevention and Control (CPC)..... | 0001 00-1 |
| Crating Instructions, Packing of Tank and | 0022 00-2 |
| D | |
| Decals and Instruction Plates, Operating Instructions on | 0005 00-6 |
| Definitions of Terms | Glossary-1 |
| Description and Use of Major Components | 0004 00-1 |
| Description and Use of Operator Controls and Indicators | 0004 00-1 |
| Destruction of Army Material to Prevent Enemy Use | 0001 00-1 |
| Differences Between Models | 0002 00-1 |
| Direct Support Maintenance Procedures | 0024 00-1 |
| Direct Support Repair; Tools; Special Tools; Test, Measurement and Diagnostic Equipment (TMDE); and Support Equipment | 0023 00-1 |
| Direct Support Troubleshooting | 0009 00-1 |
| Draining by Gravity..... | 0005 00-11 |
| Draining by Pump..... | 0005 00-11 |
| Draining the Tank..... | 0005 00-11 |
| E | |
| EIRs, Reporting | 0001 00-2 |
| Emergency Procedures..... | 0006 00-5 |
| Emergency Repair Items..... | 0002 00-2 |
| Equipment Characteristics, Capabilities and Features | 0002 00-1 |
| Equipment Data | 0002 00-1 |
| Equipment Description and Data | 0002 00-1 |
| Equipment Improvement Recommendations (EIRs), Reporting..... | 0001 00-2 |
| Equipment, Preliminary Servicing and Adjustment of..... | 0014 00-1 |
| Equipment, Special Tools, TMDE, and Support | 0013 00-1 |
| Expendable and Durable Items List | 0034 00-1 |

F

Features, Equipment Characteristics, Capabilities, and 0002 00-1
 Filler/Discharge Assembly Inspection, Repair and Replacement 0019 00-1
 Filling the Tank, Operating Procedures 0005 00-9
 Fittings 0002 00-2
 Forms, Records and Reports, Maintenance 0001 00-1

G

General Information 0001 00-1

H

Hand Grip Assembly Inspection and Replacement 0020 00-1
 How To Use This Manual iii
 Hydrostatic Test 0025 00-1

I

Information Data Plates 0002 00-2
 Installation Instructions 0014 00-1
 Installation of the Tank on the Trailer Bed 0005 00-6
 Installation of the Tie-Down Kit 0005 00-2
 Instruction Plates, Operating Instructions on Decals and 0005 00-6
 Interim Nuclear, Biological, and Chemical (NBC) Decontamination Procedures ... 0006 00-5

L

Leakage Definitions 0010 00-1
 Location and Description of Major Components 0002 00-1
 Lubrication Instructions 0012 00-1

M

Maintenance Allocation Chart 0027 00-1
 Maintenance Forms, Records and Reports 0001 00-1
 Major Components, Description and Use of 0004 00-1
 Mandatory Replacement Parts List 0036 00-1
 Movement, Preparation for 0005 00-14

N

National Stock Number Index 0030 00-1
 Nuclear, Biological, and Chemical (NBC) Decontamination
 Procedures, Interim 0006 00-5

O

Operating Instructions on Decals and Instruction Plates 0005 00-6
 Operating Procedures (Filling the Tank) 0005 00-9
 Operation at High Altitudes 0006 00-1
 Operation in Extreme Cold 0006 00-1
 Operation in Extreme Heat 0006 00-1
 Operation in High Wind 0006 00-1
 Operation in Mud 0006 00-1
 Operation in Rain 0006 00-1
 Operation in Salt Water Areas 0006 00-1

| | |
|--|-----------|
| Operation in Sandy or Dusty Areas | 0006 00-1 |
| Operation Under Unusual Conditions | 0006 00-1 |
| Operation Under Usual Conditions | 0005 00-1 |
| Operator Maintenance Procedures | 0011 00-1 |
| Operator PMCS Procedures | 0010 00-1 |
| Operator Troubleshooting Procedures..... | 0007 00-1 |

P

| | |
|--|----------------------|
| Packing of Tank and Crating Instructions | 0022 00-2 |
| Part Number Index | 0031 00-1 |
| Plates, Operating Instructions on Decals and Instruction | 0005 00-6 |
| PMCS Procedures, Operator | 0010 00-1 |
| PMCS Procedures, Unit..... | 0015 00-1 |
| Preliminary Servicing and Adjustment of Equipment..... | 0014 00-1 |
| Preparation for Movement..... | 0005 00-13 |
| Preparation for Storage or Shipment | 0001 00-2, 0022 00-1 |
| Preparation for Use, Assembly and | 0005 00-1 |
| Preservation Procedures for Storage or Shipment, Unit..... | 0022 00-1 |

Q

| | |
|--|-----------|
| Quality Assurance/Quality Control (QA/QC)..... | 0001 00-2 |
|--|-----------|

R

| | |
|---|------------|
| References | 0026 00-1 |
| Repacking | 0005 00-11 |
| Repair Parts Introduction | 0028 00-1 |
| Repair Parts List..... | 0029 00-1 |
| Reporting Equipment Improvement Recommendations (EIRs)..... | 0001 00-2 |

S

| | |
|---|----------------------|
| Scope | 0001 00-1 |
| Service Upon Receipt of Materiel | 0014 00-1 |
| Servicing and Adjustment of Equipment, Preliminary..... | 0014 00-1 |
| Shipment, Preparation for Storage or | 0022 00-1 |
| Shipment, Preservation Procedures for Storage or | 0022 00-1 |
| Special Tools, TMDE and Support Equipment | 0013 00-1, 0023 00-1 |
| Stencil Locations | 0005 00-7 |
| Storage or Shipment, Preparation for | 0022 00-1 |
| Storage or Shipment, Preservation Procedures for | 0022 00-1 |

T

| | |
|---|-----------|
| Tank Assembly, Inspection, Repair and Replacement | 0017 00-1 |
| Test, Hydrostatic | 0025 00-1 |
| Theory of Operation | 0003 00-1 |
| Tie-Down Assembly | 0002 00-2 |
| Tie-Down Assembly Inspection and Replacement | 0021 00-1 |
| Tools and Equipment, Common | 0013 00-1 |
| Tools, TMDE, and Support Equipment, Special | 0013 00-1 |
| Torque Limits | 0035 00-1 |

TM 10-5430-240-13&P

| | |
|---|-----------|
| Troubleshooting Procedures, Direct Support..... | 0009 00-1 |
| Troubleshooting Procedures, Operator..... | 0007 00-1 |
| Troubleshooting Procedures, Unit | 0008 00-1 |
| Type I Emergency Repairs..... | 0006 00-2 |
| Type II Emergency Repairs..... | 0006 00-3 |

U

| | |
|--|-----------|
| Unit Maintenance Procedures..... | 0016 00-1 |
| Unit PMCS Procedures | 0015 00-1 |
| Unit Repair; Tools; Special Tools; Test, Measurement and Diagnostic Equipment (TMDE); and Support Equipment | 0013 00-1 |
| Unit Service Upon Receipt..... | 0014 00-1 |
| Unit Troubleshooting Procedures | 0008 00-1 |
| Unpacking the Equipment..... | 0005 00-1 |
| Use, Assembly and Preparation for | 0005 00-1 |
| Use of Major Components, Description and | 0004 00-1 |

W

| | |
|--------------------------------|-----------|
| Warning Summary | a |
| Water Tank Empty | 0006 00-3 |
| Water Tank Filled | 0006 00-2 |
| Winds, Operation in High | 0006 00-1 |

By Order of the Secretary of the Army:

Official:

JOEL B. HUDSON
*Administrative Assistant to the
Secretary of the Army*
0134108

ERIC K. SHINSEKI
*General, United States Army
Chief of Staff*

To be distributed in accordance with the initial distribution number (IDN) 256709 requirements for TM 10-5430-240-13&P.

These are the instructions for sending an electronic 2028

The following format must be used if submitting an electronic 2028. The subject line must be exactly the same and all fields must be included; however, only the following fields are mandatory: 1, 3, 4, 5, 6, 7, 8, 9, 10, 13, 15, 16, 17 and 27.

From: "Whomever" whomever@avma27.army.mil
To: TACOM-TECH-PUBS@ria.army.mil

Subject DA Form 2028

1. **From:** Joe Smith
2. **Unit:** home
3. **Address:** 4300 Park
4. **City:** Hometown
5. **St:** MO
6. **Zip:** 77777
7. **Date Sent:** 19-OCT-93
8. **Pub no:** 55-1915-200-10
9. **Pub Title:** TM
10. **Publication Date:** 11-APR-88
11. **Change Number:** 12
12. **Submitter Rank:** MSG
13. **Submitter Fname:** Joe
14. **Submitter Mname:** T
15. **Submitter Lname:** Smith
16. **Submitter Phone:** 123-123-1234
17. **Problem:** 1
18. **Page:** 1
19. **Paragraph:** 3
20. **Line:** 4
21. **NSN:** 5
22. **Reference:** 6
23. **Figure:** 7
24. **Table:** 8
25. **Item:** 9
26. **Total:** 123
27. **Text:**

This is the text for the problem below line 27.

| | | | | | | | |
|---|------|------------|------|------------|-------|---|---|
| RECOMMENDED CHANGES TO PUBLICATIONS AND BLANK FORMS | | | | | | Use Part II (reverse) for Repair Parts and Special Tool Lists (RPSTL) and Supply Catalogs/Supply Manuals (SC/SM). | DATE |
| For use of this form, see AR 25-30; the proponent agency is OAASA | | | | | | | |
| TO: (Forward to proponent of publication or form) (Include ZIP Code) | | | | | | FROM: (Activity and location) (Include ZIP Code) | |
| PART I - ALL PUBLICATIONS (EXCEPT RPSTL AND SC/SM) AND BLANK FORMS | | | | | | | |
| PUBLICATION/FORM NUMBER TM 10-5430-240-13&P | | | | | | DATE 5 February 2002 | TITLE OPERATOR, UNIT AND DIRECT SUPPORT MAINTENANCE MANUAL (INCL. RPSTL) FOR COLLAPSIBLE FABRIC WATER TANK, SEMI-TRAILER MOUNTED |
| ITEM | PAGE | PARA-GRAPH | LINE | FIGURE NO. | TABLE | RECOMMENDED CHANGES AND REASON | |
| | | | | | | | |
| * Reference to line numbers within the paragraph or subparagraph. | | | | | | | |
| TYPED NAME, GRADE OR TITLE | | | | | | TELEPHONE EXCHANGE/AUTOVON, PLUS EXTENSION | SIGNATURE |

| | | |
|--|---|------|
| TO: (Forward direct to addressee listed in publication) | FROM: (Activity and location) (Include ZIP Code) | DATE |
|--|---|------|

PART II - REPAIR PARTS AND SPECIAL TOOL LISTS AND SUPPLY CATALOGS/SUPPLY MANUALS

| | | |
|--------------------|------|-------|
| PUBLICATION NUMBER | DATE | TITLE |
|--------------------|------|-------|

| PAGE NO. | COLM NO. | LINE NO. | NATIONAL STOCK NUMBER | REFERENCE NO. | FIGURE NO. | ITEM NO. | TOTAL NO. OF MAJOR ITEMS SUPPORTED | RECOMMENDED ACTION |
|----------|----------|----------|-----------------------|---------------|------------|----------|------------------------------------|--------------------|
| | | | | | | | | |

PART III - REMARKS (Any general remarks or recommendations, or suggestions for improvement of publications and blank forms. Additional blank sheets may be used if more space is needed.)

| | | |
|----------------------------|--|-----------|
| TYPED NAME, GRADE OR TITLE | TELEPHONE EXCHANGE/AUTOVON, PLUS EXTENSION | SIGNATURE |
|----------------------------|--|-----------|

| RECOMMENDED CHANGES TO PUBLICATIONS AND BLANK FORMS | | | | | | Use Part II (<i>reverse</i>) for Repair Parts and Special Tool Lists (RPSTL) and Supply Catalogs/Supply Manuals (SC/SM). | DATE |
|---|------|------------|------|------------|-------|--|---|
| For use of this form, see AR 25-30; the proponent agency is OAASA | | | | | | | |
| TO: (<i>Forward to proponent of publication or form</i>) (<i>Include ZIP Code</i>) | | | | | | FROM: (<i>Activity and location</i>) (<i>Include ZIP Code</i>) | |
| PART I - ALL PUBLICATIONS (EXCEPT RPSTL AND SC/SM) AND BLANK FORMS | | | | | | | |
| PUBLICATION/FORM NUMBER TM 10-5430-240-13&P | | | | | | DATE 5 February 2002 | TITLE OPERATOR, UNIT AND DIRECT SUPPORT MAINTENANCE MANUAL (INCL. RPSTL) FOR COLLAPSIBLE FABRIC WATER TANK, SEMI-TRAILER MOUNTED |
| ITEM | PAGE | PARA-GRAPH | LINE | FIGURE NO. | TABLE | RECOMMENDED CHANGES AND REASON | |
| | | | | | | | |
| <i>* Reference to line numbers within the paragraph or subparagraph.</i> | | | | | | | |
| TYPED NAME, GRADE OR TITLE | | | | | | TELEPHONE EXCHANGE/AUTOVON, PLUS EXTENSION | SIGNATURE |

| | | |
|--|---|------|
| TO: (Forward direct to addressee listed in publication) | FROM: (Activity and location) (Include ZIP Code) | DATE |
|--|---|------|

PART II - REPAIR PARTS AND SPECIAL TOOL LISTS AND SUPPLY CATALOGS/SUPPLY MANUALS

| | | |
|--------------------|------|-------|
| PUBLICATION NUMBER | DATE | TITLE |
|--------------------|------|-------|

| PAGE NO. | COLM NO. | LINE NO. | NATIONAL STOCK NUMBER | REFERENCE NO. | FIGURE NO. | ITEM NO. | TOTAL NO. OF MAJOR ITEMS SUPPORTED | RECOMMENDED ACTION |
|----------|----------|----------|-----------------------|---------------|------------|----------|------------------------------------|--------------------|
| | | | | | | | | |

PART III - REMARKS (Any general remarks or recommendations, or suggestions for improvement of publications and blank forms. Additional blank sheets may be used if more space is needed.)

| |
|--|
| |
|--|

| | | |
|----------------------------|--|-----------|
| TYPED NAME, GRADE OR TITLE | TELEPHONE EXCHANGE/AUTOVON, PLUS EXTENSION | SIGNATURE |
|----------------------------|--|-----------|

| | | |
|---|--|------|
| RECOMMENDED CHANGES TO PUBLICATIONS AND BLANK FORMS For use of this form, see AR 25-30; the proponent agency is OAASA | Use Part II (<i>reverse</i>) for Repair Parts and Special Tool Lists (RPSTL) and Supply Catalogs/Supply Manuals (SC/SM). | DATE |
|---|--|------|

| | |
|---|---|
| TO: (<i>Forward to proponent of publication or form</i>) (<i>Include ZIP Code</i>) | FROM: (<i>Activity and location</i>) (<i>Include ZIP Code</i>) |
|---|---|

| | | |
|---|-------------------------|---|
| PART I - ALL PUBLICATIONS (EXCEPT RPSTL AND SC/SM) AND BLANK FORMS | | |
| PUBLICATION/FORM NUMBER TM 10-5430-240-13&P | DATE 5 February 2002 | TITLE OPERATOR, UNIT AND DIRECT SUPPORT MAINTENANCE MANUAL (INCL. RPSTL) FOR COLLAPSIBLE FABRIC WATER TANK, SEMI-TRAILER MOUNTED |

| ITEM | PAGE | PARA-GRAPH | LINE | FIGURE NO. | TABLE | RECOMMENDED CHANGES AND REASON |
|------|------|------------|------|------------|-------|--------------------------------|
| | | | | | | |

* *Reference to line numbers within the paragraph or subparagraph.*

| | | |
|----------------------------|--|-----------|
| TYPED NAME, GRADE OR TITLE | TELEPHONE EXCHANGE/AUTOVON, PLUS EXTENSION | SIGNATURE |
|----------------------------|--|-----------|

| | | |
|---|--|------|
| TO: <i>(Forward direct to addressee listed in publication)</i> | FROM: <i>(Activity and location) (Include ZIP Code)</i> | DATE |
|---|--|------|

PART II - REPAIR PARTS AND SPECIAL TOOL LISTS AND SUPPLY CATALOGS/SUPPLY MANUALS

| PUBLICATION NUMBER | | | DATE | TITLE | | | | |
|--------------------|----------|----------|-----------------------|---------------|------------|----------|------------------------------------|--------------------|
| PAGE NO. | COLM NO. | LINE NO. | NATIONAL STOCK NUMBER | REFERENCE NO. | FIGURE NO. | ITEM NO. | TOTAL NO. OF MAJOR ITEMS SUPPORTED | RECOMMENDED ACTION |
| | | | | | | | | |

PART III - REMARKS *(Any general remarks or recommendations, or suggestions for improvement of publications and blank forms. Additional blank sheets may be used if more space is needed.)*

| | | | | | | | | |
|----------------------------|--|--|--|--|--|-----------|--|--|
| TYPED NAME, GRADE OR TITLE | | | TELEPHONE EXCHANGE/AUTOVON, PLUS EXTENSION | | | SIGNATURE | | |
|----------------------------|--|--|--|--|--|-----------|--|--|

The Metric System and Equivalents

Linear Measure

1 centimeter = 10 millimeters = .39 inch
 1 decimeter = 10 centimeters = 3.94 inches
 1 meter = 10 decimeters = 39.37 inches
 1 dekameter = 10 meters = 32.8 feet
 1 hectometer = 10 dekameters = 328.08 feet
 1 kilometer = 10 hectometers = 3,280.8 feet

Weights

1 centigram = 10 milligrams = .15 grain
 1 decigram = 10 centigrams = 1.54 grains
 1 gram = 10 decigrams = .035 ounce
 1 dekagram = 10 grams = .35 ounce
 1 hectogram = 10 dekagrams = 3.52 ounces
 1 kilogram = 10 hectograms = 2.2 pounds
 1 quintal = 100 kilograms = 220.46 pounds
 1 metric ton = 10 quintals = 1.1 short tons

Liquid Measure

1 centiliter = 10 milliliters = .34 fl. ounce
 1 deciliter = 10 centiliters = 3.38 fl. ounces
 1 liter = 10 deciliters = 33.81 fl. ounces
 1 dekaliter = 10 liters = 2.64 gallons
 1 hectoliter = 10 dekaliters = 26.42 gallons
 1 kiloliter = 10 hectoliters = 264.18 gallons

Square Measure

1 sq. centimeter = 100 sq. millimeters = .155 sq. inch
 1 sq. decimeter = 100 sq. centimeters = 15.5 sq. inches
 1 sq. meter (centare) = 100 sq. decimeters = 10.76 sq. feet
 1 sq. dekameter (are) = 100 sq. meters = 1,076.4 sq. feet
 1 sq. hectometer (hectare) = 100 sq. dekameters = 2.47 acres
 1 sq. kilometer = 100 sq. hectometers = .386 sq. mile

Cubic Measure

1 cu. centimeter = 1000 cu. millimeters = .06 cu. inch
 1 cu. decimeter = 1000 cu. centimeters = 61.02 cu. inches
 1 cu. meter = 1000 cu. decimeters = 35.31 cu. feet

Approximate Conversion Factors

| To change | To | Multiply by | To change | To | Multiply by |
|---------------|--------------------|-------------|--------------------|---------------|-------------|
| inches | centimeters | 2.540 | ounce-inches | newton-meters | .007062 |
| feet | meters | .305 | centimeters | inches | .394 |
| yards | meters | .914 | meters | feet | 3.280 |
| miles | kilometers | 1.609 | meters | yards | 1.094 |
| square inches | square centimeters | 6.451 | kilometers | miles | .621 |
| square feet | square meters | .093 | square centimeters | square inches | .155 |
| square yards | square meters | .836 | square meters | square feet | 10.764 |
| square miles | square kilometers | 2.590 | square meters | square yards | 1.196 |
| acres | square hectometers | .405 | square kilometers | square miles | .386 |
| cubic feet | cubic meters | .028 | square hectometers | acres | 2.471 |
| cubic yards | cubic meters | .765 | cubic meters | cubic feet | 35.315 |
| fluid ounces | milliliters | 29.573 | cubic meters | cubic yards | 1.308 |
| pints | liters | .473 | milliliters | fluid ounces | .034 |
| quarts | liters | .946 | liters | pints | 2.113 |
| gallons | liters | 3.785 | liters | quarts | 1.057 |
| ounces | grams | 28.349 | liters | gallons | .264 |
| pounds | kilograms | .454 | grams | ounces | .035 |
| short tons | metric tons | .907 | kilograms | pounds | 2.205 |
| pound-feet | newton-meters | 1.356 | metric tons | short tons | 1.102 |
| pound-inches | newton-meters | .11296 | | | |

Temperature (Exact)

°F Fahrenheit temperature 5/9 (after subtracting 32) Celsius temperature °C

PIN: 079453-000